

# MAESTRO 2/2M

## Ersatzteilliste Spare Parts List

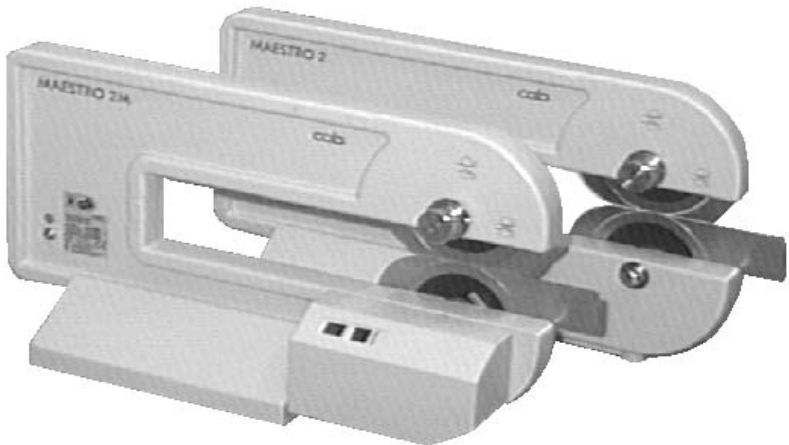

**MAESTRO 2**  
**Nutzentrenner für vorgeritzte Leiterplatten**  
**Circuit Board Cutter for pre-scored PCB's**

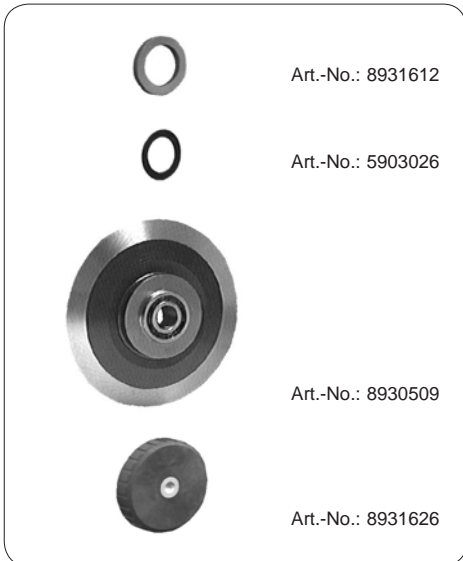
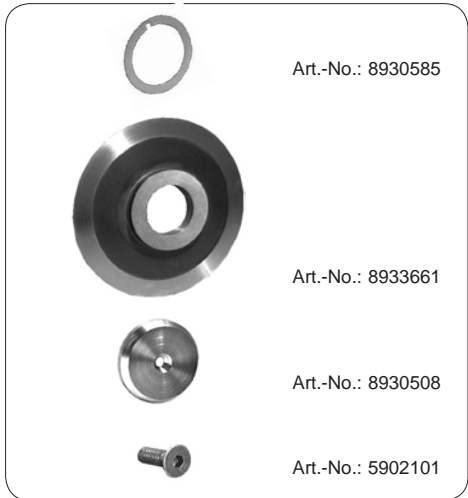
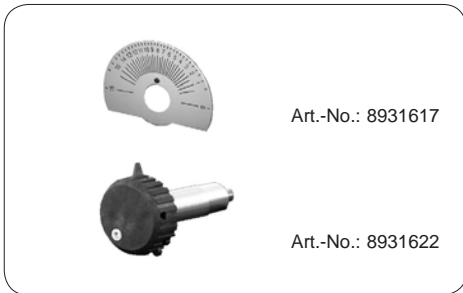
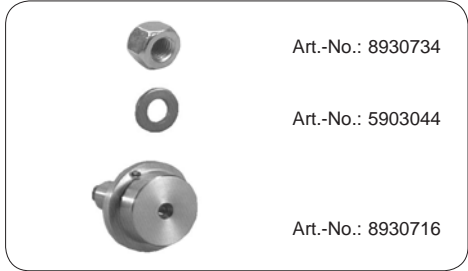
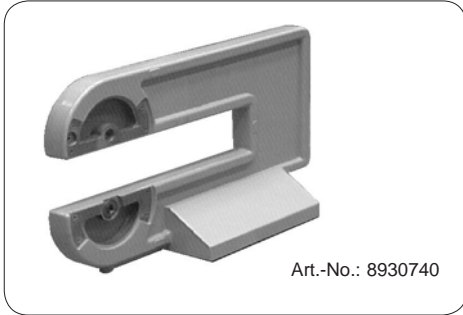

## MAESTRO 2

### Nutzentrenner für vorgeritzte Leiterplatten Circuit Board Cutter for pre-scored PCB's

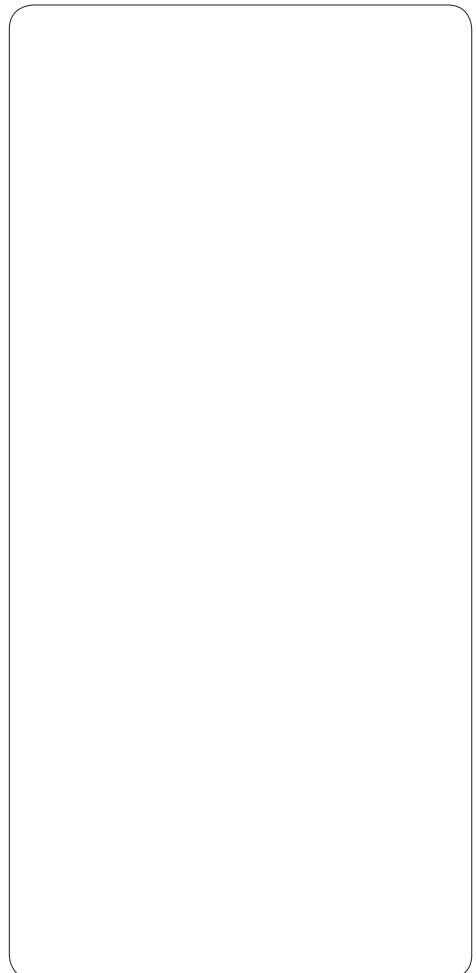

# MAESTRO 2M

## Nutzentrenner für vorgeritzte Leiterplatten Circuit Board Cutter for pre-scored PCB's

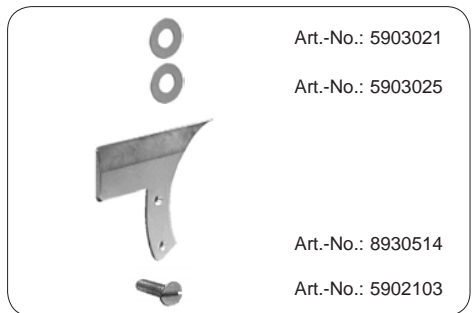
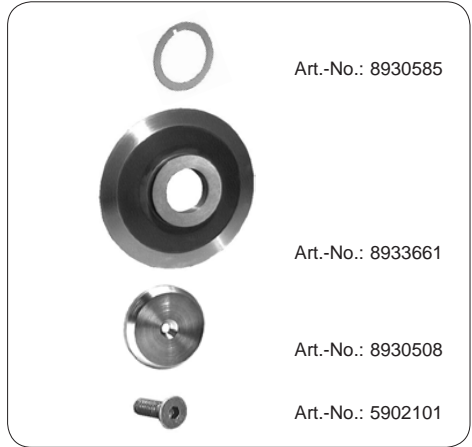
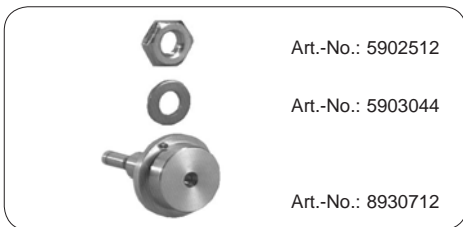
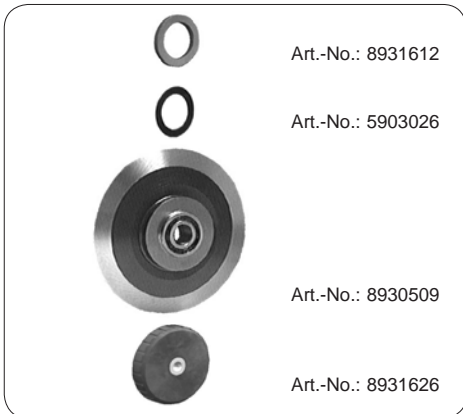
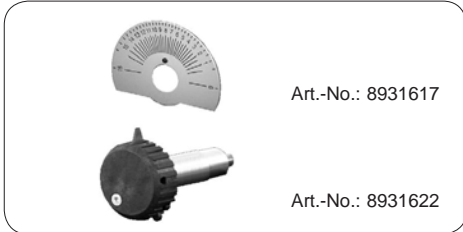
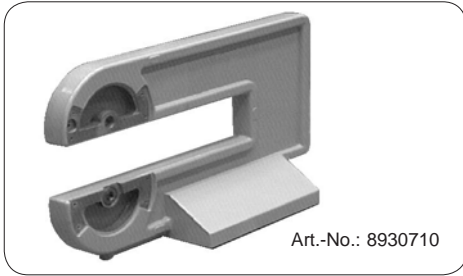

# MAESTRO 2M

## Nutzentrenner für vorgeritzte Leiterplatten

## Circuit Board Cutter for pre-scored PCB's

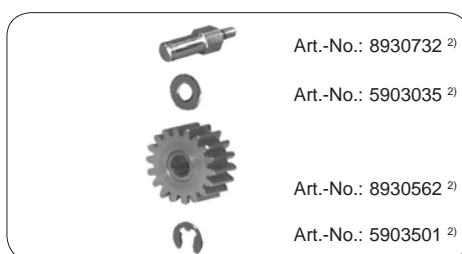
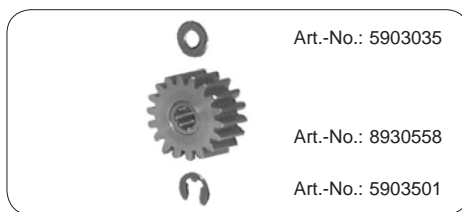
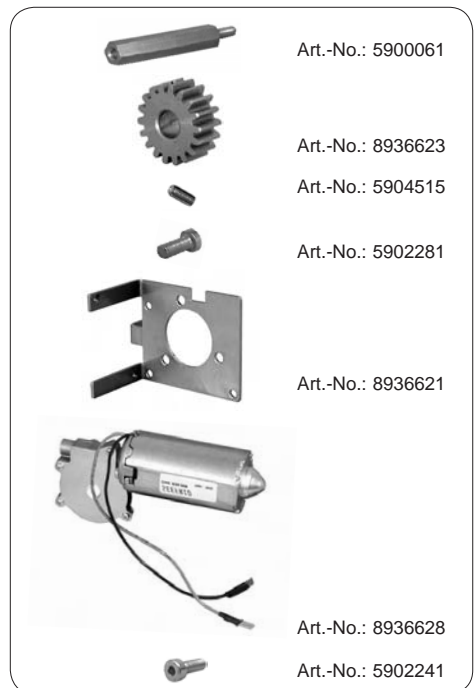
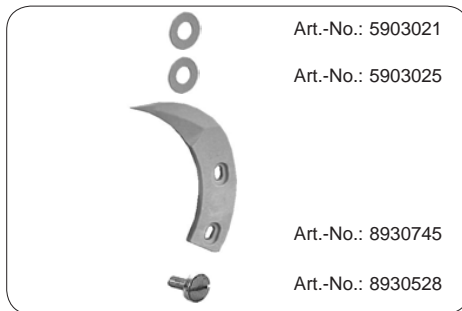
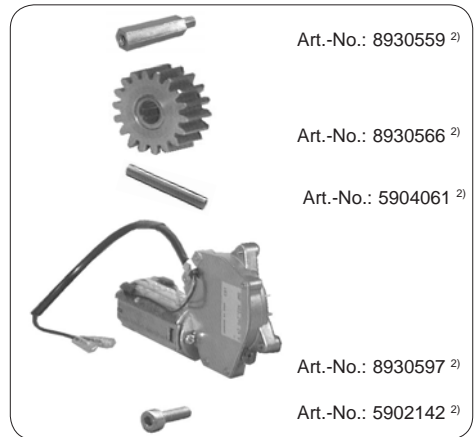
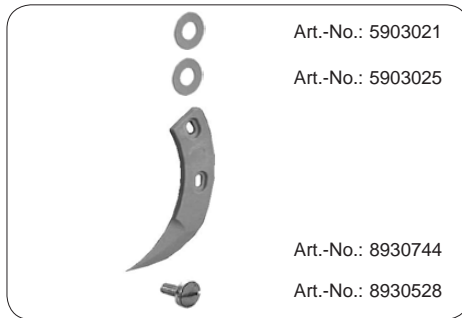

<sup>1)</sup> Geräte MAESTRO 2M bis Serien-Nr. 821 / Machines MAESTRO 2M up to serial-no. 821

<sup>2)</sup> Geräte MAESTRO 2M bis Serien-Nr. 1996 / Machines MAESTRO 2M up to serial-no. 1996.

# MAESTRO 2M

## Nutzentrenner für vorgeritzte Leiterplatten

## Circuit Board Cutter for pre-scored PCB's

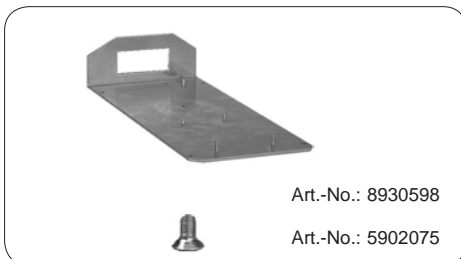
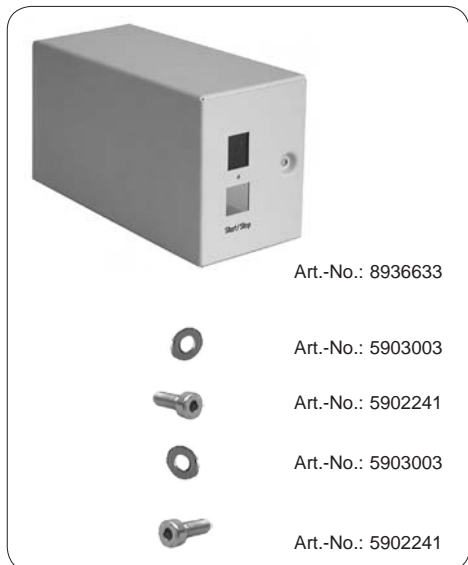
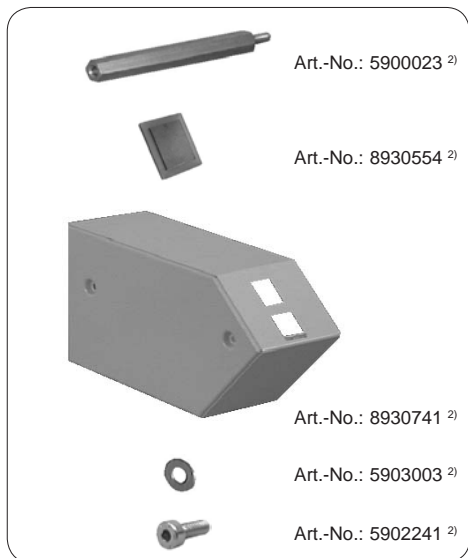

<sup>1)</sup> Geräte MAESTRO 2M bis Serien-Nr. 821 / Machines MAESTRO 2M up to serial-no. 821

<sup>2)</sup> Geräte MAESTRO 2M bis Serien-Nr. 1996 / Machines MAESTRO 2M up to serial-no. 1996.

# MAESTRO 2M

## Nutzentrenner für vorgeritzte Leiterplatten

## Circuit Board Cutter for pre-scored PCB's

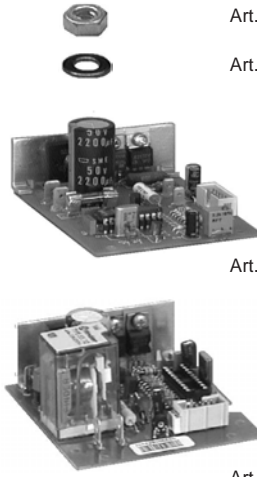

Art.-No.: 5902505

Art.-No.: 5903004

Art.-No.: 8930571 <sup>1)</sup>

Art.-No.: 8932507

Art.-No.: 5900516



Art.-No.: 8930715



Art.-No.: 5902510

Art.-No.: 5903011

Art.-No.: 5903033

Art.-No.: 5916907

Art.-No.: 5916915



Art.-No.: 5902501

Art.-No.: 5903011

Art.-No.: 5903520

Art.-No.: 8930713

Art.-No.: 5902135



Art.-No.: 5901505



Art.-No.: 5550611



Art.-No.: 5909002

<sup>1)</sup> Geräte MAESTRO 2M bis Serien-Nr. 821 / Machines MAESTRO 2M up to serial-no. 821

<sup>2)</sup> Geräte MAESTRO 2M bis Serien-Nr. 1996 / Machines MAESTRO 2M up to serial-no. 1996.

## MAESTRO 2 / 2M

### Nutzentrenner für vorgeritzte Leiterplatten Circuit Board Cutter for pre-scored PCB's

Art.-No.	Bezeichnung	Stück/Gerät		Bild auf Seite
		MAESTRO 2	MAESTRO 2M	
5550611	Netzkabel	-	1	7
5900023	Abstandsbolzen M4x60	-	2	6
5900061	Abstandsbolzen M4x25-B	-	3	6
5900514	Distanzhülse PA M3x8	-	4 <sup>2)</sup>	6
5900516	Distanzhülse PA M3x5	-	2	7
5901505	Kabelbinder L=102mm	-	1	7
5901574	Kabelhalter für Ø 9,6 selbstklebend	-	2	6
5902075	Senkschraube DIN965-M4x8-4.8-galZn	-	4	6
5902101	Senkschraube DIN7991-M6x16-8.8-galZn	1	1	2, 4
5902103	Senkschraube DIN963-M4x14-galZn	2	2	3, 4
5902135	Senkschraube DIN965-M4x40-4.8-galZn	-	1	7
5902142	Zylinderschraube DIN912-M5x20-8.8-galZn	-	3 <sup>2)</sup>	5
5902241	Zylinderschraube DIN7984-M4x10-8.8-galZn	-	2	6
5902241	Zylinderschraube DIN7984-M4x10-8.8-galZn	-	3	5
5902281	Zylinderschraube DIN7984-M5x12-8.8-galZn	-	3	5
5902501	Sechskantmutter DIN934-M4-8-galZn	-	1	7
5902505	Sechskantmutter DIN934-M3-8-galZn	-	4 <sup>2)</sup>	6
5902505	Sechskantmutter DIN934-M3-8-galZn	-	4	7
5902510	Sechskantmutter DIN934-M4-CuZn-galNi	-	1	7
5902512	Sechskantmutter DIN439-B-M10-galZn	-	1	4
5903003	Scheibe DIN125-A4.3-galZn	-	2	6
5903004	Scheibe DIN125-A3.2-galZn	-	4 <sup>2)</sup>	6
5903004	Scheibe DIN125-A3.2-galZn	-	4	7
5903010	Federscheibe DIN137-A6	2	2	2, 4
5903011	Zahnscheibe DIN6797-A4.3-galZn	-	2	7
5903021	Passscheibe DIN988-6x12x0.1	6	6	3, 4, 5
5903025	Passscheibe DIN988-6x12x0.2	12	12	3, 4, 5
5903026	Passscheibe DIN988-15x21x0.1	4	4	2, 4
5903033	Scheibe DIN125-4.3-CuZn-galNi	-	1	7
5903035	Passscheibe DIN988-8x14x1.0	-	1	5
5903035	Passscheibe DIN988-8x14x1.0	-	1 <sup>2)</sup>	5
5903044	Scheibe DIN125-A10.5-galZn	1	1	2, 4
5903077	Scheibe 3.2x8.1.5-Hgw	-	1 <sup>2)</sup>	6
5903501	Sicherungsscheibe DIN6799-7-galZn	-	1	5
5903501	Sicherungsscheibe DIN6799-7-galZn	-	1 <sup>2)</sup>	5
5903520	Scheibe DIN7349-4.3-galZn	-	1	7
5904061	Zylinderkerbstift DIN1473-3x20-5.8	-	1 <sup>2)</sup>	5
5904515	Gewindestift DIN913-M4x8-45H	-	1	5
5909002	Innensechskantschlüssel DIN911 2mm	1	1	3, 7
5916907	Sicherung 5x20 1.0 A T	-	2	7
5916915	Sicherung 5x20 500 mA T	-	2	7
8930508	Klemmscheibe	1	1	2, 4

<sup>1)</sup> Geräte MAESTRO 2M bis Serien-Nr. 821

<sup>2)</sup> Geräte MAESTRO 2M bis Serien-Nr. 1996

# MAESTRO 2 / 2M

## Nutzentrenner für vorgeritzte Leiterplatten

### Circuit Board Cutter for pre-scored PCB's

Art.-No.	Bezeichnung	Stück/Gerät		Bild auf Seite
		MAESTRO 2	MAESTRO 2M	
8930509	Rollmesser TiN	1	1	2, 4
8930514	Führung, unten	1	1	3, 4
8930517	Verpackung	1	1	-
8930522	Niederhalter, kpl.	1	1	2, 4
8930528	Ansatzschraube	4	4	3, 5
8930554	Fenster	-	1 <sup>2)</sup>	6
8930558	Zahnrad mit Freilauf	-	1	5
8930559	Stehbolzen	-	3 <sup>2)</sup>	5
8930562	Zahnrad, kpl.	-	1 <sup>2)</sup>	5
8930566	Zahnrad Motor	-	1 <sup>2)</sup>	5
8930571	Leiterplatte Steuerung	-	1 <sup>1)</sup>	7
8930585	Distanzring	4	4	2, 4
8930590	Ansatzschraube	2	2	2, 4
8930597	Motor, kpl.	-	1 <sup>2)</sup>	5
8930598	Boden mit Bolzen	-	1	6
8930702	Scheibe	8	8	2, 4
8930708	Bedienungsanleitung MAESTRO 2M	-	1	-
8930710	Gestell, kpl.	-	1	4
8930712	Messerwelle, kpl.	-	1	4
8930713	Trafo, kpl.	-	1	7
8930715	Netzeingangsmodul, kpl.	-	1	7
8930716	Messerwelle 2, kpl.	1	-	2
8930724	Bedienungsanleitung MAESTRO 2	1	-	-
8930732	Lagerbolzen	-	1 <sup>2)</sup>	5
8930734	Hutmutter	1	-	2
8930739	Leiterplatte Bedienfeld	-	1 <sup>1)</sup>	6
8930740	Gestell 2, kpl.	1	-	2
8930741	Haube	-	1 <sup>2)</sup>	6
8930744	Messerschutz oben	1	1	3, 5
8930745	Messerschutz unten	1	1	3, 5
8931612	Scheibe	1	1	2, 4
8931617	Skale	1	1	2, 4
8931622	Verstellmechanismus	1	1	2, 4
8931626	Rändelmutter, kpl.	1	1	2, 4
8932502	Leiterplatte Anzeige	-	1	6
8932507	Leiterplatte Steuerung, kpl.	-	1	7
8933661	Rollmesser TiN	1	1	2, 4
8936621	Motorblech	-	1	5
8936623	Zahnrad	-	1	5
8936628	Motor, kpl.	-	1	5
8936633	Haube, kpl.	-	1	6

<sup>1)</sup> Geräte MAESTRO 2M bis Serien-Nr. 821

<sup>2)</sup> Geräte MAESTRO 2M bis Serien-Nr. 1996

## MAESTRO 2 / 2M

### Nutzentrenner für vorgeritzte Leiterplatten Circuit Board Cutter for pre-scored PCB's

Part No.	Description	Quantity per device		Picture on page
		MAESTRO 2	MAESTRO 2M	
5550611	Power Cable	-	1	7
5900023	Distance Bolt M4x60	-	2	6
5900061	Distance Bolt M4x25-B	-	3	6
5900514	Spacer Bushing PA M3x8	-	4 <sup>2)</sup>	6
5900516	Spacer Bushing PA M3x5	-	2	7
5901505	Cable Clamp L=102mm	-	1	7
5901574	Cable Clamp for Ø 9,6 adhesive	-	2	6
5902075	Flush Screw DIN965-M4x8-4.8-galZn	-	4	6
5902101	Flush Screw DIN7991-M6x16-8.8-galZn	1	1	2, 4
5902103	Flush Screw DIN963-M4x14-galZn	2	2	3, 4
5902135	Flush Screw DIN965-M4x40-4.8-galZn	-	1	7
5902142	Screw DIN912-M5x20-8.8-galZn	-	3 <sup>2)</sup>	5
5902241	Screw DIN7984-M4x10-8.8-galZn	-	2	6
5902241	Screw DIN7984-M4x10-8.8-galZn	-	3	5
5902281	Screw DIN7984-M5x12-8.8-galZn	-	3	5
5902501	Nut DIN934-M4-8-galZn	-	1	7
5902505	Nut DIN934-M3-8-galZn	-	4 <sup>2)</sup>	6
5902505	Nut DIN934-M3-8-galZn	-	4	7
5902510	Nut DIN934-M4-CuZn-galNi	-	1	7
5902512	Nut DIN439-B-M10-galZn	-	1	4
5903003	Washer DIN125-A4.3-galZn	-	2	6
5903004	Washer DIN125-A3.2-galZn	-	4 <sup>2)</sup>	6
5903004	Washer DIN125-A3.2-galZn	-	4	7
5903010	Spring Washer DIN137-A6	2	2	2, 4
5903011	Washer DIN6797-A4.3-galZn	-	2	7
5903021	Washer DIN988 6x12x0.1	6	6	3, 4, 5
5903025	Washer DIN988-6x12x0.2	12	12	3, 4, 5
5903026	Washer DIN988-15x21x0.1	4	4	2, 4
5903033	Washer DIN125-4.3-CuZn-galNi	-	1	7
5903035	Washer DIN988-8x14x1.0	-	1	5
5903035	Washer DIN988-8x14x1.0	-	1 <sup>2)</sup>	5
5903044	Washer DIN125-A10.5-galZn	1	1	2, 4
5903077	Washer 3.2x8.1.5-Hgw	-	1 <sup>2)</sup>	6
5903501	E-Ring DIN6799-7-galZn	-	1	5
5903501	E-Ring DIN6799-7-galZn	-	1 <sup>2)</sup>	5
5903520	Washer DIN7349-4.3-galZn	-	1	7
5904061	Grooved Pin DIN1473-3x20-5.8	-	1 <sup>2)</sup>	5
5904515	Set Screw DIN913-M4x8-45H	-	1	5
5909002	Allen Key DIN911 2mm	1	1	3, 7
5916907	Fuse 5x20 1.0 A T	-	2	7
5916915	Fuse 5x20 500 mA T	-	2	7
8930508	Plate	1	1	2, 4

<sup>1)</sup> Machines MAESTRO 2M up to serial-no. 821

<sup>2)</sup> Machines MAESTRO 2M up to serial-no. 1996.

# MAESTRO 2 / 2M

## Nutzentrenner für vorgeritzte Leiterplatten

## Circuit Board Cutter for pre-scored PCB's

Part No.	Description	Quantity per device		Picture on page
		MAESTRO 2	MAESTRO 2M	
8930509	Circular (Upper) Blade TiN	1	1	2, 4
8930514	Guide	1	1	3, 4
8930517	Packaging	1	1	-
8930522	Holder	1	1	2, 4
8930528	Screw	4	4	3, 5
8930554	Window	-	1 <sup>2)</sup>	6
8930558	Gear Wheel	-	1	5
8930559	Distance Bolt	-	3 <sup>2)</sup>	5
8930562	Gear Wheel	-	1 <sup>2)</sup>	5
8930566	Gear Wheel (motor)	-	1 <sup>2)</sup>	5
8930571	PCB, control	-	1 <sup>1)</sup>	7
8930585	Washer	4	4	2, 4
8930590	Screw	2	2	2, 4
8930597	Motor	-	1 <sup>2)</sup>	5
8930598	Baseplate	-	1	6
8930702	Washer	8	8	2, 4
8930708	Operating Manual MAESTRO 2M	-	1	-
8930710	Frame	-	1	4
8930712	Blade Shaft	-	1	4
8930713	Transformer	-	1	7
8930715	Fused Main Connector	-	1	7
8930716	Blade Shaft 2	1	-	2
8930724	Operating Manual MAESTRO 2	1	-	-
8930732	Bolt	-	1 <sup>2)</sup>	5
8930734	Nut	1	-	2
8930739	PCB, display	-	1 <sup>1)</sup>	6
8930740	Frame 2	1	-	2
8930741	Bonnet	-	1 <sup>2)</sup>	6
8930744	Upper Shield	1	1	3, 5
8930745	Lower Shield	1	1	3, 5
8931612	Washer	1	1	2, 4
8931617	Scale	1	1	2, 4
8931622	Adjusting Mechanism	1	1	2, 4
8931626	Knurled Nut	1	1	2, 4
8932502	PCB, display	-	1	6
8932507	PCB, control	-	1	7
8933661	Circular (Lower) Blade TiN	1	1	2, 4
8936621	Motor Plate	-	1	5
8936623	Gear Wheel	-	1	5
8936628	Motor	-	1	5
8936633	Bonnet	-	1	6

<sup>1)</sup> Machines MAESTRO 2M up to serial-no. 821

<sup>2)</sup> Machines MAESTRO 2M up to serial-no. 1996.

**Art.-Nr. :** 9008017

### **Urheberrecht**

Diese Dokumentation sowie Übersetzungen hiervon sind Eigentum der cab Produkttechnik GmbH & Co KG. Das Reproduzieren, Verarbeiten, Vervielfältigen oder Verbreiten im Ganzen oder in Teilen zu anderen Zwecken als der Verfolgung seiner ursprünglichen bestimmungsgemäßen Verwendung - insbesondere die Ersatzteilbeschaffung eines von cab verkauften Gerätes - erfordert die vorherige schriftliche Genehmigung der cab.

### **Redaktion**

Bei Fragen oder Anregungen wenden Sie sich bitte an cab Produkttechnik GmbH & Co KG Adresse „Deutschland“.

### **Aktualität**

Durch die ständige Weiterentwicklung der Geräte können Abweichungen zwischen der Dokumentation und dem Gerät auftreten. Die aktuelle Ausgabe finden Sie unter [www.cabgmbh.com](http://www.cabgmbh.com).

### **Geschäftsbedingungen**

Lieferungen und Leistungen erfolgen zu den „Allgemeinen Verkaufsbedingungen der cab“.

### **Copyright**

This documentation as well as translation hereof are property of cab Produkttechnik GmbH & Co. KG. The replication, conversion, duplication or divulgement of the whole manual or parts of it for other intentions than its original intended purpose - in particular the procurement of spare parts for products sold by cab – demand the previous written authorisation by cab.

### **Editor**

Regarding questions or comments please contact cab Produkttechnik GmbH & Co. KG.

### **Topicality**

Due to the constant further development of our products discrepancies between documentation and product can occur.

Please check [www.cabgmbh.com](http://www.cabgmbh.com) for the latest update.

### **Terms and conditions**

Deliveries and performances are effected under the “General conditions of sale of cab”



cab-Produkttechnik  
Gesellschaft für  
Computer und Automations-  
bausteine mbH & Co KG

Postfach 19 04 D-76007 Karlsruhe  
Wilhelm-Schickard-Straße 14 D-76131 Karlsruhe  
Telefon 0721 / 66 26-111  
Telefax 0721 / 66 26-119