

11.3 DETAILED DRAWINGS OF PREFORMING UNITS

11.3.1. DETAILED DRAWING OF DIE ASSEMBLY STAND OFF LOCK IN COD. 180600

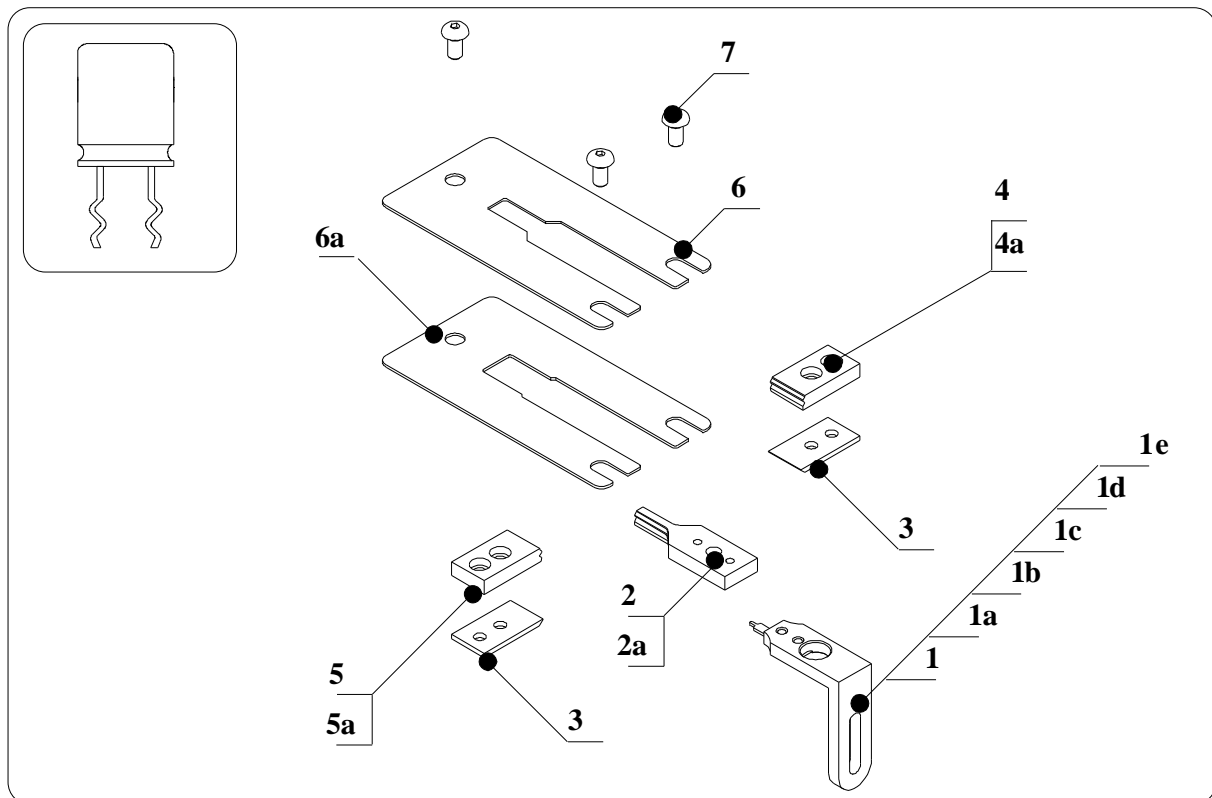

11.3.1.1 DETAILED SPARE PARTS LIST DIE ASSEMBLY STAND OFF LOCK IN COD. 180600

Pos.	Article	Description	Qty
1	180040	<u>COMPLETE PREFORMING ADJUSTER FROM P=2 TO P=10,16</u>	1
1a	160018	REFERENCE HOLDER FROM P=2 TO P=10,16	1
1b	160019	PREFORMING REFERENCE FROM P=2 TO P=10,16	1
1c	500006	CS SCREW M3X8	2
1d	780517	KNOB FC-M3	1
1e	160047	SCREW TS M3x10	1
2	160603	DIE P. 2,54 STAND OFF LOCK IN	1
2	160604	DIE P. 5,08 STAND OFF LOCK IN	1
2	160605	DIE P. 7,62 STAND OFF LOCK IN	1
2	160606	DIE P. 10,16 STAND OFF LOCK IN	1
2a	550012	BH SCREW M5X15	1
3	160607	CUTTING BLADES TP/SC4	2
4	160601	RIGHT PUNCH STAND OFF LOCK IN	1
4a	150210	REDUCED CAPSCREW M4X10	2
5	160602	LEFT PUNCH STAND OFF LOCK IN	1
5a	150210	REDUCED CAPSCREW M4X10	2
6	180106	SAFETY PROTECTION FOR PITCHES FROM 2 TO 5.08	1
6a	180107	SAFETY PROTECTION FOR PITCHES FROM 7.62 TO 10.16	1
7	500070	SCREW TBEI M5X8	3

**11.3.2. DETAILED DRAWING OF DIE ASSEMBLY STAND OFF LOCK IN LED
COD. 180700**

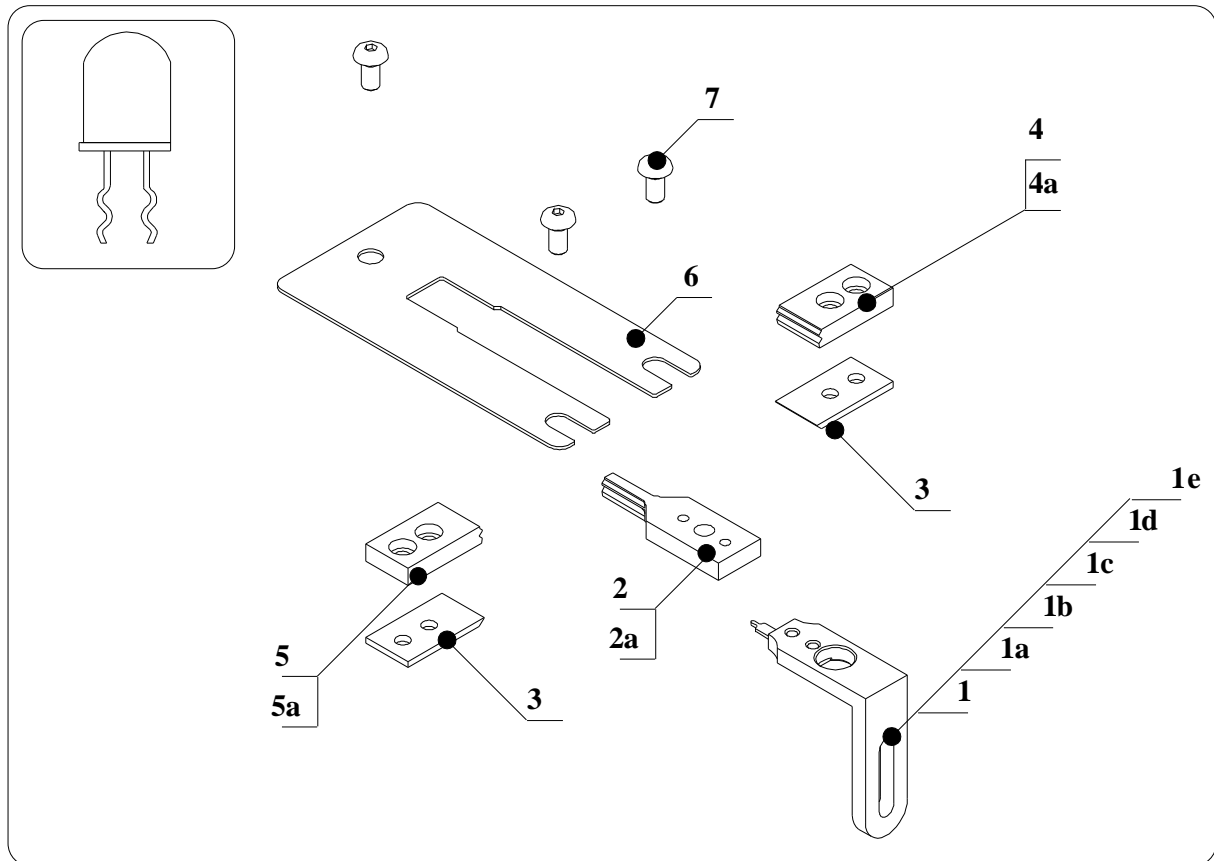

**11.3.2.1 DETAILED SPARE PARTS LIST OF DIE ASSEMBLY STAND OFF LOCK IN LED
COD. 180700**

Pos.	Article	Description	Qty
<u>1</u>	<u>180040</u>	<u>COMPLETE PREFORMING ADJUSTER FROM P=2 TO P=10,16</u>	<u>1</u>
1a	160018	REFERENCE HOLDER FROM P=2 TO P=10,16	1
1b	160019	PREFORMING REFERENCE FROM P=2 TO P=10,16	1
1c	500006	CS SCREW M3X8	2
1d	780517	KNOB FC-M3	1
1e	160047	SCREW TS M3x10	1
2	160703	DIE P. 2MM STAND OFF LOCK IN	1
2a	550012	BH SCREW M5X15	1
3	160607	CUTTING BLADES TP/SC4	2
4	160701	RIGHT FORMING PUNCH P. 2MM STAND OFF LOCK IN-LED	1
4a	150210	REDUCED CAPSCREW M4X10	2
5	160702	LEFT FORMING PUNCH P. 2MM STAND OFF LOCK IN-LED	1
5a	150210	REDUCED CAPSCREW M4X10	2
6	180107	SAFETY PROTECTION FOR PITCHES FROM 7.62 TO 10.16	1
7	500070	SCREW TBEI M5X8	3

**11.3.3. DETAILED DRAWING OF DIE ASSEMBLY STAND OFF - KINK OTWARDS
COD. 180800**

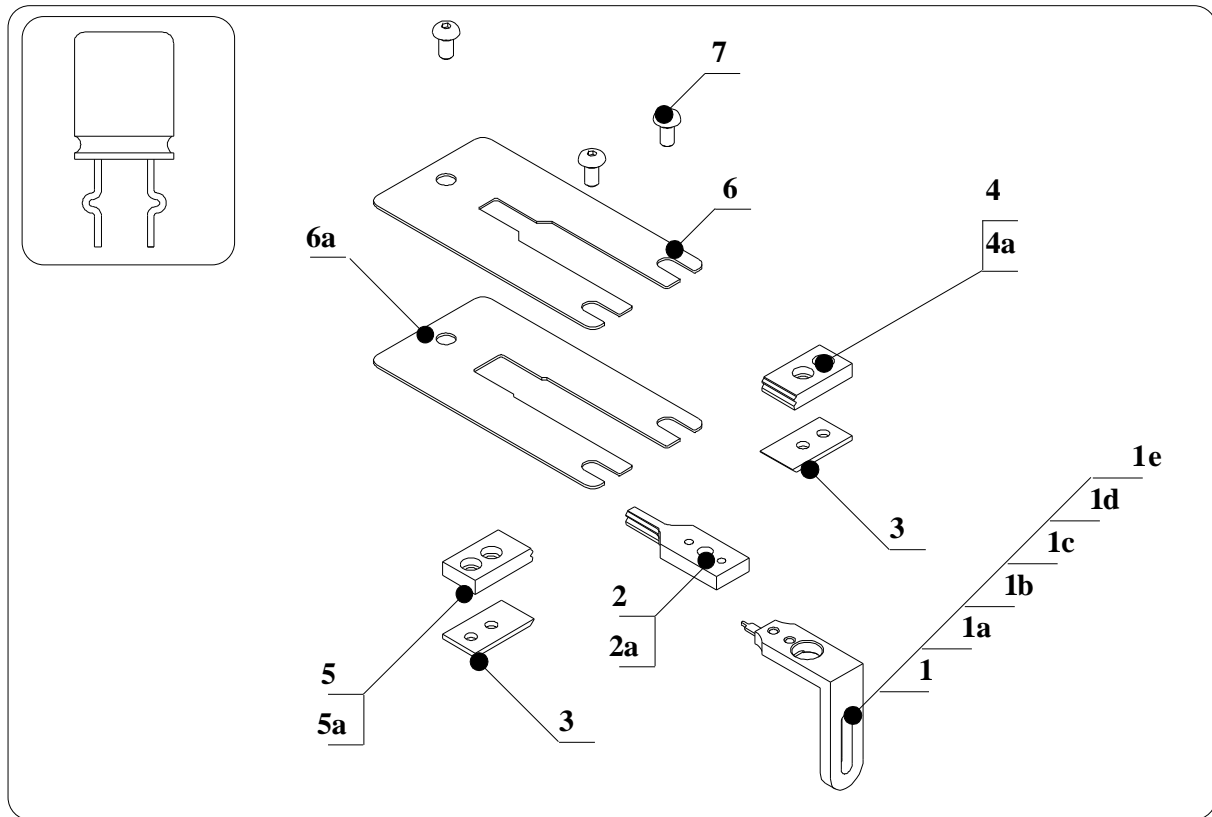

**11.3.3.1 DETAILED SPARE PARTS LIST OF DIE ASSEMBLY STAND OFF - KINK OTWARD
COD. 180800**

Pos.	Article	Description	Qty
1	180040	COMPLETE PREFORMING ADJUSTER FROM P=2 TO P=10,16	1
1a	160018	REFERENCE HOLDER FROM P=2 TO P=10,16	1
1b	160019	PREFORMING REFERENCE FROM P=2 TO P=10,16	1
1c	500006	CS SCREW M3X8	2
1d	780517	KNOB FC-M3	1
1e	160047	SCREW TS M3x10	1
2	160803	DIE P. 2 STAND OFF KINK OUTWARDS	1
2	160804	DIE P. 2,54 STAND OFF KINK OUTWARDS	1
2	160805	DIE P. 5,08 STAND OFF KINK OUTWARDS	1
2	160806	DIE P. 7,62 STAND OFF KINK OUTWARDS	1
2	160807	DIE P. 10,16 STAND OFF KINK OUTWARDS	1
2a	550012	BH SCREW M5X15	1
3	160607	CUTTING BLADES TP/SC4	2
4	160801	RIGHTFORMING PUNCH STAND OFF KINK OUTWARDS	1
4a	150210	REDUCED CAPSCREW M4X10	2
5	160802	LEFTFORMING PUNCH STAND OFF KINK OUTWARDS	1
6a	150210	REDUCED CAPSCREW M4X10	2
6	180106	SAFETY PROTECTION FOR PITCHES FROM 2 TO 5.08	1
6a	180107	SAFETY PROTECTION FOR PITCHES FROM 7.62 TO 10.16	1
7	500070	SCREW TBEI M5X8	3

**11.3.4. DETAILED DRAWING OF DIE ASSEMBLY BODY LOCKED ON PCB
COD. 180900**

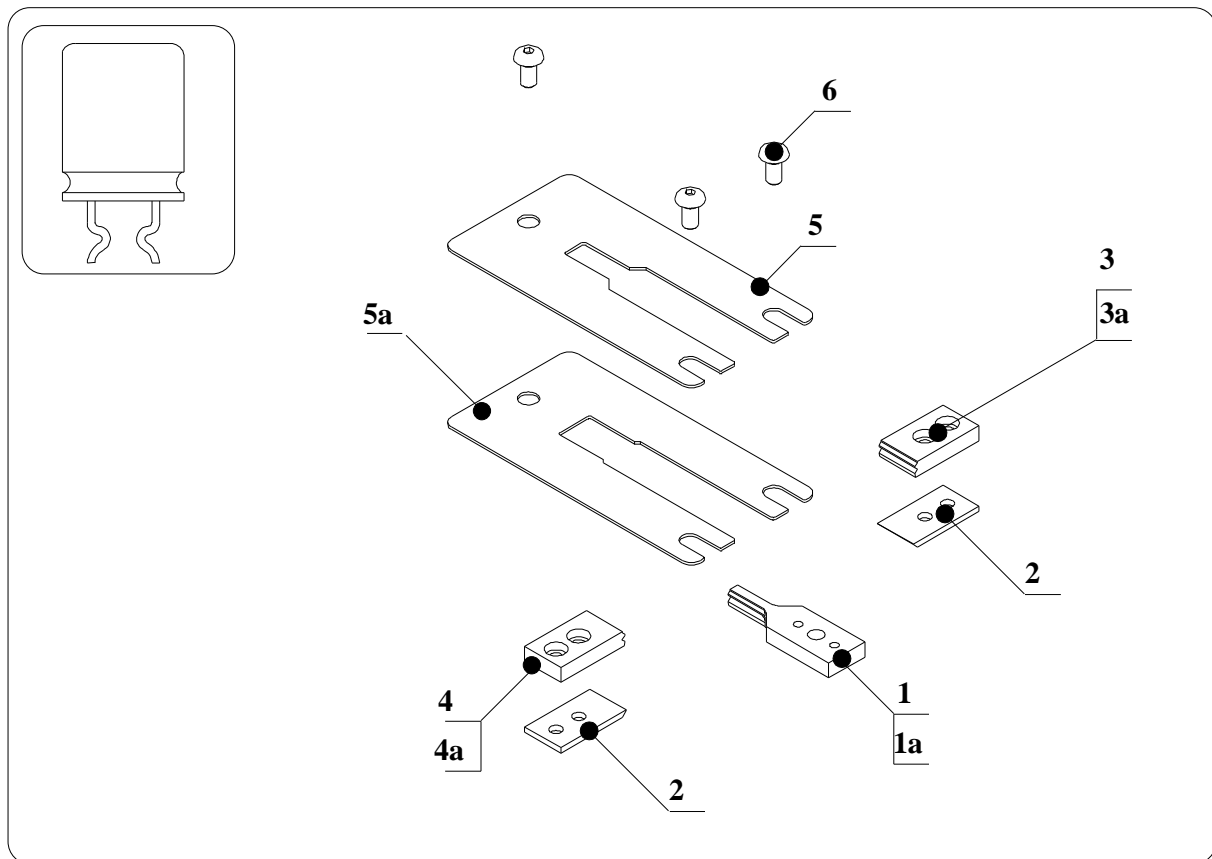

11.3.4.1 DETAILED SPARE PARTS LIST OF DIE ASSEMBLY BODY LOCKED ON PCB COD. 180900

Pos.	Article	Description	Qty
1	160903	DIE P. 2,54 BODY LOCKED ON PCB	1
1	160904	DIE P. 5,08 BODY LOCKED ON PCB	1
1	160905	DIE P. 7,62 BODY LOCKED ON PCB	1
1	160906	DIE P. 10,16 BODY LOCKED ON PCB	1
1a	750302	BH SCREW M5X12	1
2	160607	CUTTING BLADES TP/SC4	2
3	160901	RIGHT FORMING PUNCH BODY LOCKED ON P.C.B.	1
3a	150210	REDUCED CAPSCREW M4X10	2
4	160902	LEFT FORMING PUNCH BODY LOCKED ON P.C.B.	1
4a	150210	REDUCED CAPSCREW M4X10	2
6	180106	SAFETY PROTECTION FOR PITCHES FROM 2 TO 5.08	1
6a	180107	SAFETY PROTECTION FOR PITCHES FROM 7.62 TO 10.16	1
7	500070	SCREW TBEI M5X8	3

11.3.5. DETAILED DRAWING OF DIE ASSEMBLY STRAIGHT CUT COD. 181000

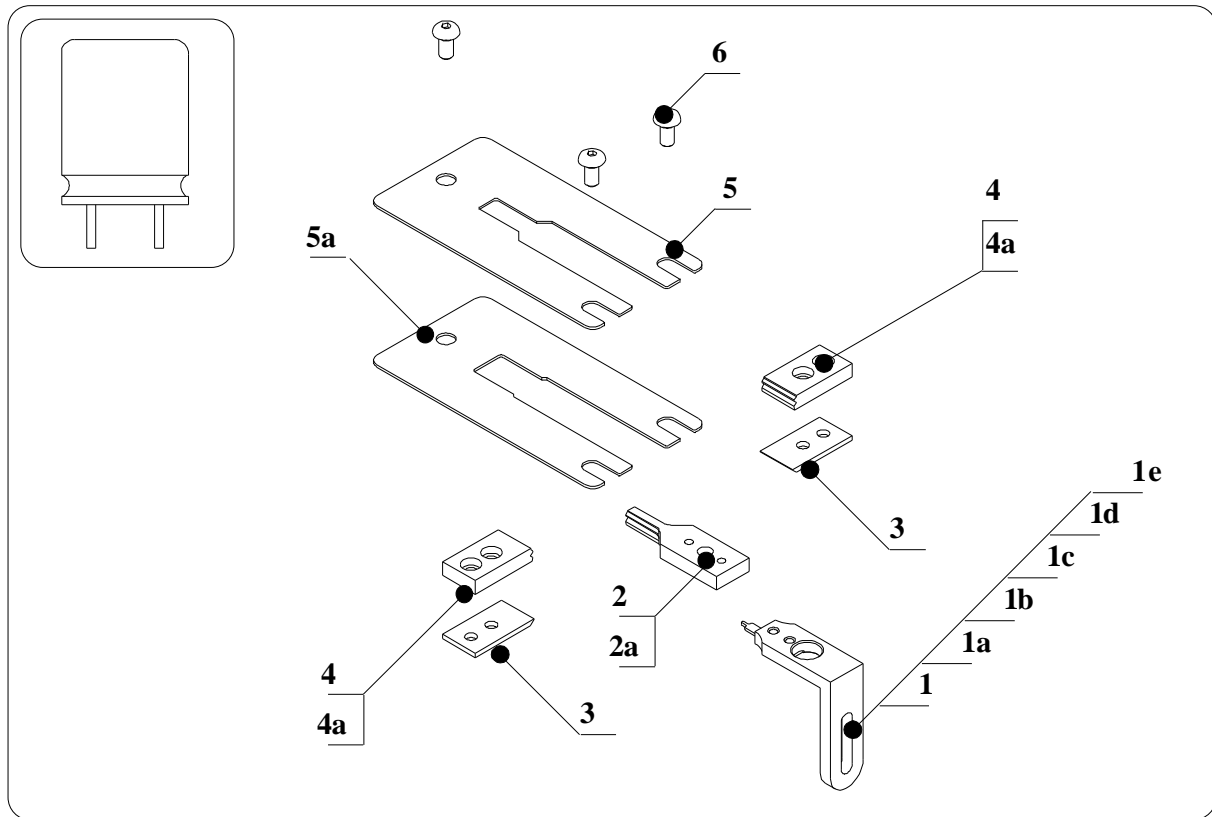

11.3.5.1 DETAILED SPARE PARTS LIST OF DIE ASSEMBLY STRAIGHT CUT COD. 181000

Ref.	Item	Description	Qty
1	180040	COMPLETE PREFORMING ADJUSTER FROM P=2 TO P=10,16	1
1a	160018	REFERENCE HOLDER FROM P=2 TO P=10,16	1
1b	160019	PREFORMING REFERENCE FROM P=2 TO P=10,16	1
1c	500006	CS SCREW M3X8	2
1d	780517	KNOB FC-M3	1
1e	160047	SCREW TS M3x10	1
2	161002	DIE P. 2,54 STRAIGHT CUT	1
2	161003	DIE P. 5,08 STRAIGHT CUT	1
2	161004	DIE P. 7,62 STRAIGHT CUT	1
2	161005	DIE P. 10,16 STRAIGHT CUT	1
2a	750302	BH SCREW M5X12	1
3	160607	CUTTING BLADES TP/SC4	2
4	161001	SIDE PUNCH STRAIGHT CUT	2
4a	150210	REDUCED CAPSCREW M4X10	4
6	180106	SAFETY PROTECTION FOR PITCHES FROM 2 TO 5.08	1
6a	180107	SAFETY PROTECTION FOR PITCHES FROM 7.62 TO 10.16	1
7	500070	SCREW TBEI M5X8	3

11.3.6. DETAILED DRAWING OF PREFORMING UNIT COD. 181100
four leads diode bridge

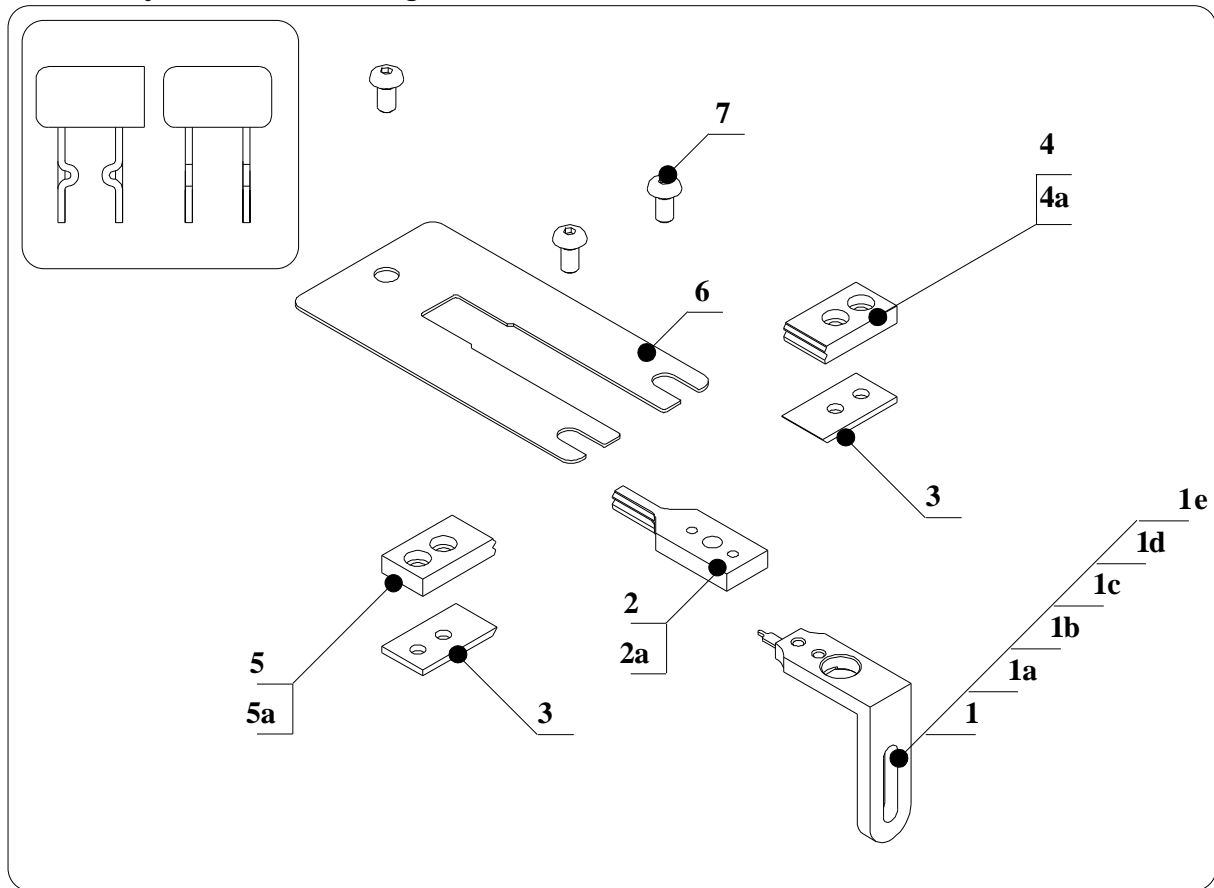

11.3.6.1 DETAILED SPARE PARTS LIST OF PREFORMING UNIT COD. 181100

Ref.	Item	Description	Qty
<u>1</u>	<u>180040</u>	<u>COMPLETE PREFORMING ADJUSTER FROM P=2 TO P=10,16</u>	<u>1</u>
1a	160018	REFERENCE HOLDER FROM P=2 TO P=10,16	1
1b	160019	PREFORMING REFERENCE FROM P=2 TO P=10,16	1
1c	500006	CS SCREW M3X8	2
1d	780517	KNOB FC-M3	1
1e	160047	SCREW TS M3x10	1
2	161101	DIE DIODE BRIDGE 4 LEADS P=5,08	1
2a	550012	BH SCREW M5X15	1
3	160607	CUTTING BLADE TP/SC4	2
4	161510	RIGHT FORMING PUNCH STAND OFF KINK INWARDS P. 2-2,54	1
4a	150210	REDUCED CAPSCREW M4X10	2
5	161511	LEFT FORMING PUNCH STAND OFF KINK INWARDS P. 2-2,54	1
5a	150210	REDUCED CAPSCREW M4X10	2
6	180107	SAFETY PROTECTION FOR PITCHES FROM 7.62 TO 10.16	1
7	500070	SCREW TBEI M5X8	3

11.3.7. DETAILED DRAWING OF PREFORMING UNIT COD. 181200 POLARITY

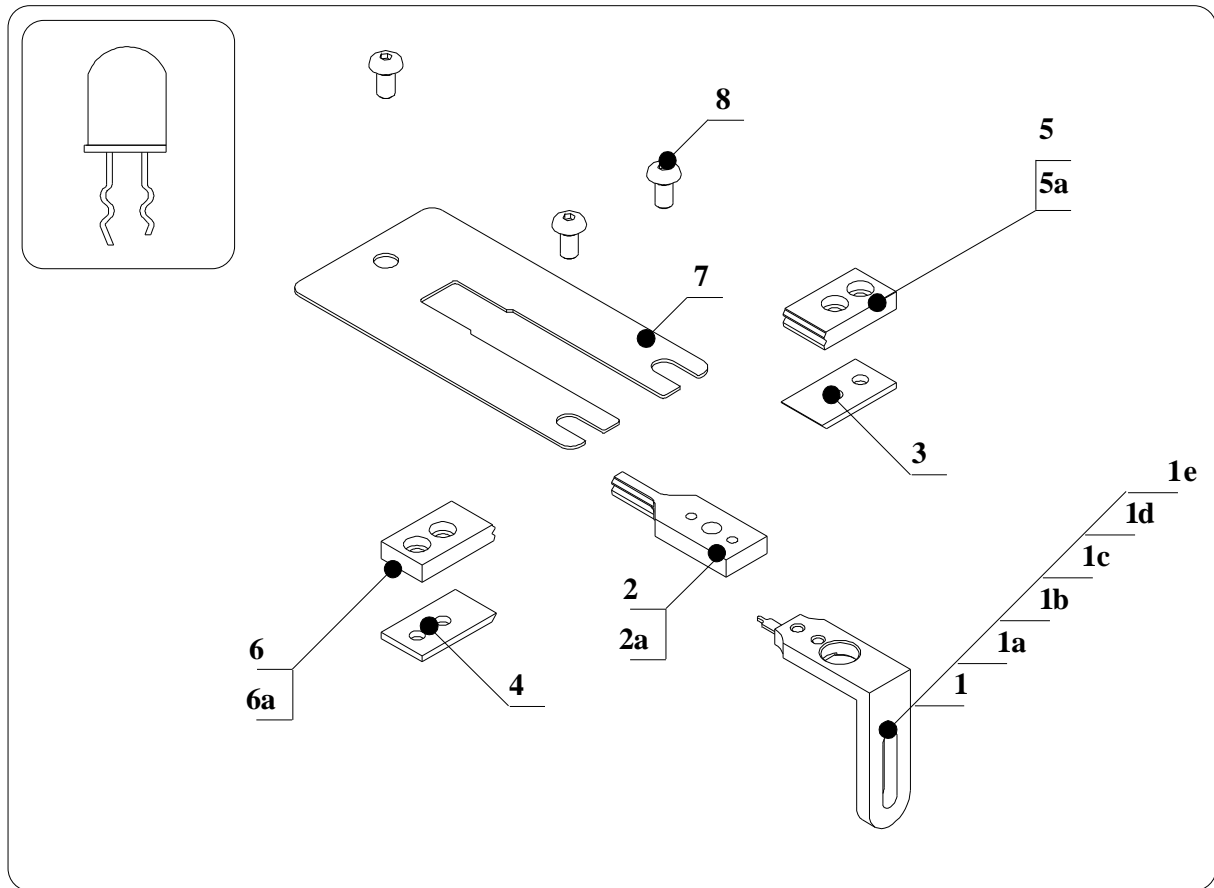

11.3.7.1 DETAILED SPARE PARTS LIST OF PREFORMING UNIT COD. 181200

Ref.	Item	Description	Qty
<u>1</u>	<u>180040</u>	<u>COMPLETE PREFORMING ADJUSTER FROM P=2 TO P=10,16</u>	<u>1</u>
1a	160018	REFERENCE HOLDER FROM P=2 TO P=10,16	1
1b	160019	PREFORMING REFERENCE FROM P=2 TO P=10,16	1
1c	500006	CS SCREW M3X8	2
1d	780517	KNOB FC-M3	1
1e	160047	SCREW TS M3x10	1
2	161205	DIE P. 2,54 POLARITY	1
2a	550012	BHSCREW M5X15	1
3	160607	CUTTINGBLADE TP/SC4	1
4	161202	LEFTCUTTINGBLADE POLARITY	1
5	161201	RIGHT FORMING PUNCH POLARITY	1
5a	150210	REDUCEDCAPSCREW M4X10	2
6	161203	LEFT FORMING PUNCH POLARITY	1
6a	150210	REDUCEDCAPSCREW M4X10	2
7	180107	SAFETY PROTECTION FOR PITCHES FROM 7.62 TO 10.16	1
8	500070	SCREW TBEI M5X8	3

11.3.8. DETAILED DRAWING OF PREFORMING UNIT COD. 181300 90° BENDING

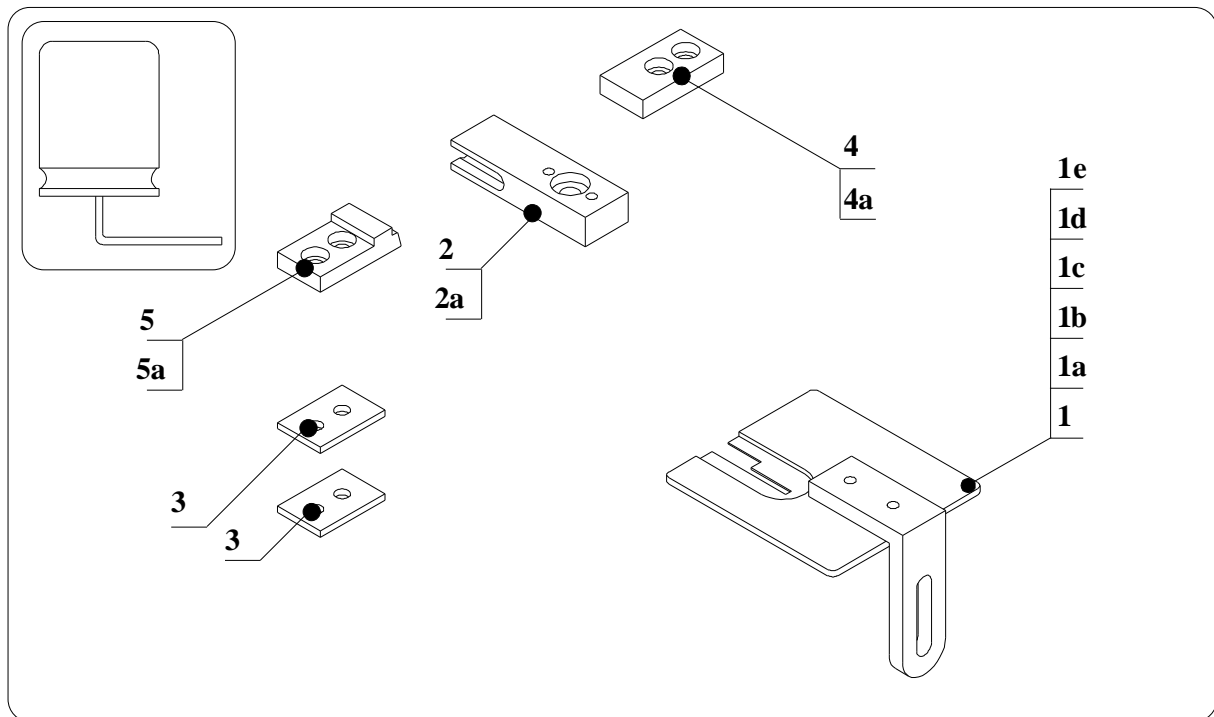

11.3.8.1 DETAILED SPARE PARTS LIST OF PREFORMING UNIT COD. 181300

Ref.	Item	Description	Qty
1	180041	COMPLETE PREFORMING ADJUSTERSMD COMPONENTS AND 90° BENDING	1
1a	160021	REFERENCE HOLDER FOR SMD / 90° BENDING/ TO220	1
1b	160022	PREFORMING REFERENCE FOR SMD AND 90° BENDING	1
1c	160047	SCREW TS M3x10	2
1d	400116	NUT M3	1
1e	780517	KNOB FC-M3	1
2	161301	DIE 90° BENDING	1
2a	550012	BH SCREW M5X15	1
3	160016	THICKNESS PLATE	2
4	161403	RIGHT FORMING PUNCH	1
4a	150210	REDUCED CAPSCREW M4X10	2
5	161302	CUTTING FORMING PUNCH 90° BENDING	1
5a	150210	REDUCED CAPSCREW M4X10	2

11.3.9. DETAILED DRAWING OF PREFORMING UNIT COD. 181400 SURFACE MOUNTING

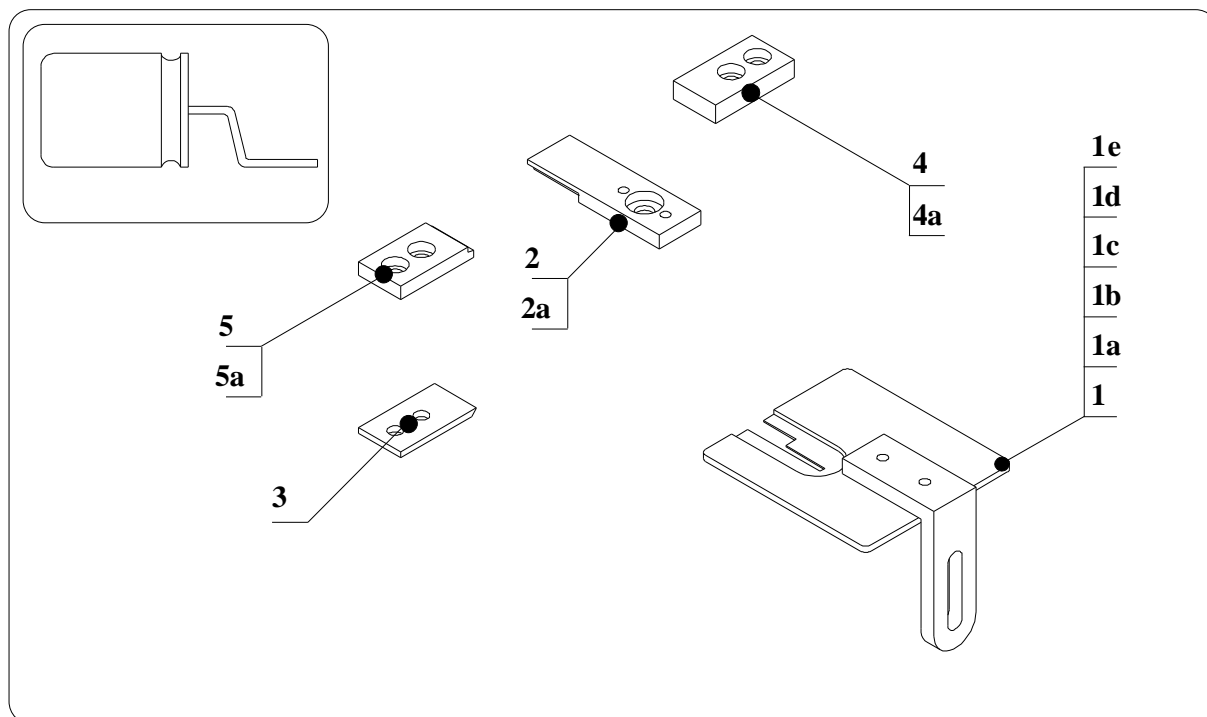

11.3.9.1 DETAILES SPARE PARTS LIST OF PREFORMING UNIT COD. 181400

Ref.	Item	Description	Q.ty
1	180041	COMPLETE PREFORMING ADJUSTERSMD COMPONENTS AND 90° BENDING	1
1a	160021	REFERENCE HOLDER FOR SMD / 90° BENDING/ TO220	1
1b	160022	PREFORMING REFERENCE FOR SMD AND 90° BENDING	1
1c	160047	SCREW TS M3x10	2
1d	400116	NUT M3	1
1e	780517	KNOB FC-M3	1
2	161402	DIE SURFACE MOUNTING	1
2a	750302	BH SCREW M5X12	1
3	160607	CUTTING BLADE TP/SC4	2
4	161403	RIGHT FORMING PUNCH	1
4a	150210	REDUCED CAPSCREW M4X10	2
5	161401	LEFT FORMING PUNCH SURFACE MOUNTING	1
5a	150210	REDUCED CAPSCREW M4X10	2

11.3.10. DETAILED DRAWING OF PREFORMING UNIT COD. 181500
STAND OFF - KINK INWARDS

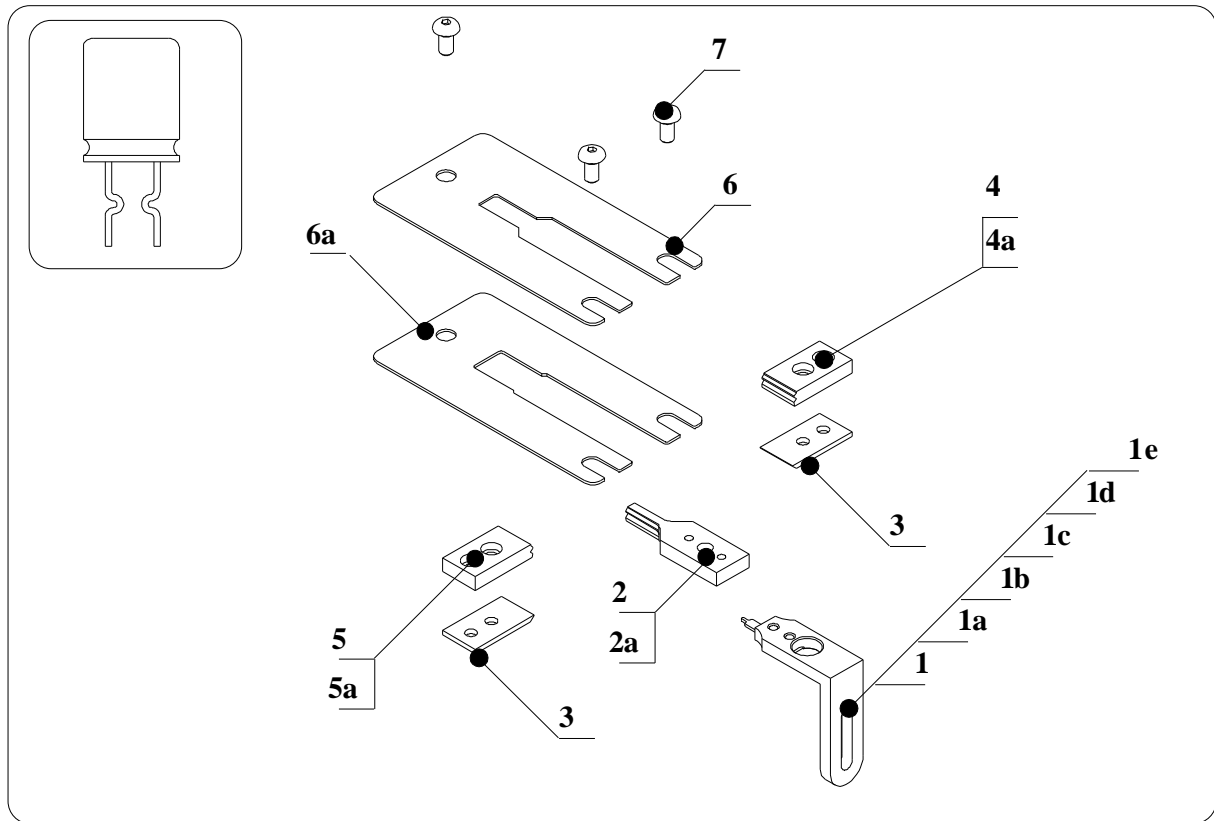

11.3.10.1 DETAILED SPARE PARTS LIST OF PREFORMING UNIT COD. 181500

Ref.	Item	Description	Qty
1	180040	COMPLETE PREFORMING ADJUSTER FROM P=2 TO P=10,16	1
1a	160018	REFERENCE HOLDER FROM P=2 TO P=10,16	1
1b	160019	PREFORMING REFERENCE FROM P=2 TO P=10,16	1
1c	500006	CS SCREW M3X8	2
1d	780517	KNOB FC-M3	1
1e	160047	SCREW TS M3x10	1
2	161503	DIE P. 2,54 STAND OFF KINK INWARDS	1
2	161505	DIE P. 5,08 STAND OFF KINK INWARDS	1
2	161506	DIE P. 7,62 STAND OFF KINK INWARDS	1
2	161507	DIE P. 10,16 STAND OFF KINK INWARDS	1
2a	550012	BH SCREW M5X15	1
3	160607	CUTTING BLADE TP/SC4	2
4	161510	RIGHT FORMING PUNCH STAND OFF KINK INWARDS P. 2-2,54	1
4	161508	RIGHT FORMING PUNCH STAND OFF KINK INWARDS 5,08-10,16	1
4a	150210	REDUCED CAPSCREW M4X10	2
5	161511	LEFT FORMING PUNCH STAND OFF KINK INWARDS P. 2-2,54	1
5	161509	LEFT FORMING PUNCH STAND OFF KINK INWARDS 5,08-10,16	1
5a	150210	REDUCED CAPSCREW M4X10	2
6	180106	SAFETY PROTECTION FOR PITCHES FROM 2 TO 5.08	1
6a	180107	SAFETY PROTECTION FOR PITCHES FROM 7.62 TO 10.16	1
7	500070	SCREW TBEI M5X8	3

11.3.11. DETAILED DRAWING OF PREFORMING UNIT COD. 181700 TO SPREAD OUT AND CUT

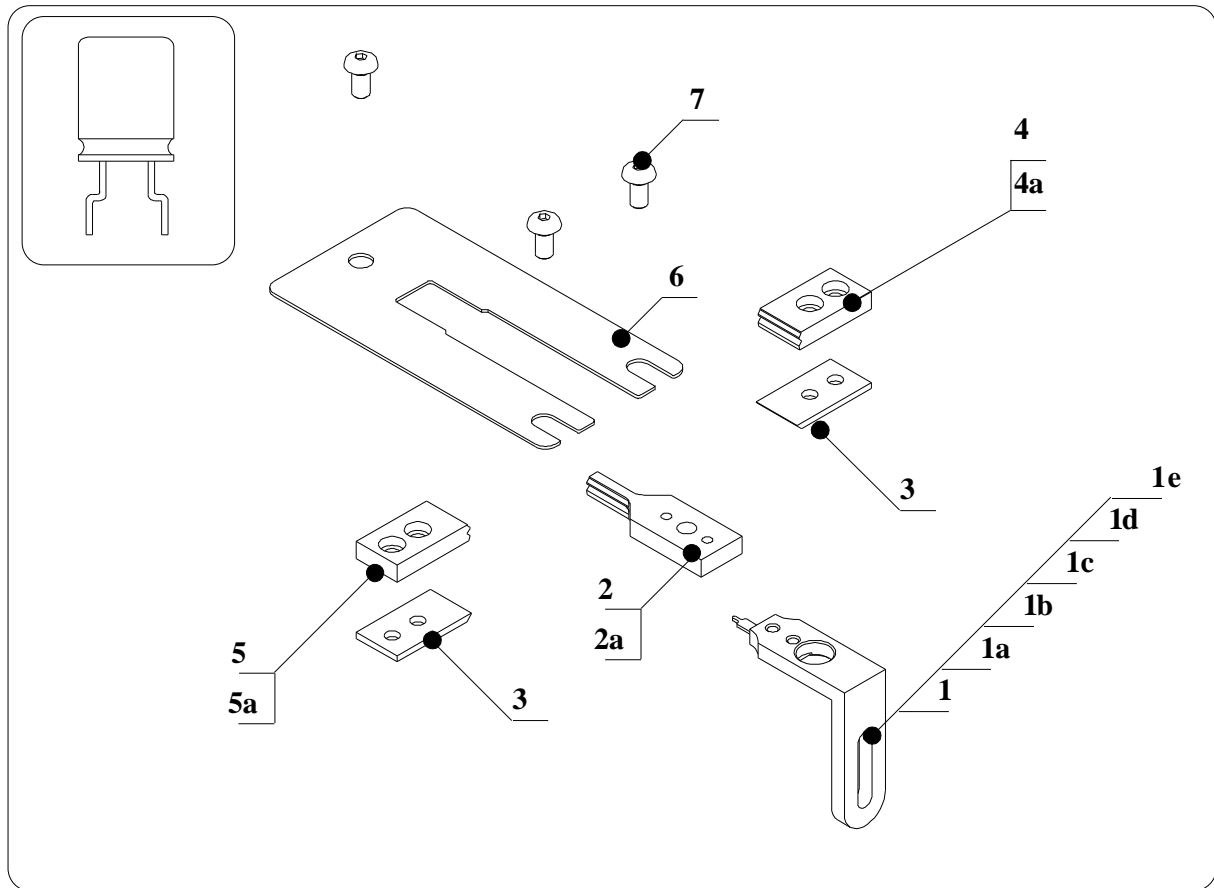

11.3.11.1 DETAILED SPARE PARTS LIST OF PREFORMING UNIT COD. 181700

Ref.	Item	Description	Qty
<u>1</u>	<u>180040</u>	<u>COMPLETE PREFORMING ADJUSTER FROM P=2 TO P=10,16</u>	<u>1</u>
1a	160018	REFERENCE HOLDER FROM P=2 TO P=10,16	1
1b	160019	PREFORMING REFERENCE FROM P=2 TO P=10,16	1
1c	500006	CS SCREW M3X8	2
1d	780517	KNOB FC-M3	1
1e	160047	SCREW TS M3x10	1
2	161703	DIE TO SPREAD OUT AND CUT	1
2a	550012	BH SCREW M5X15	1
3	160607	CUTTING BLADE TP/SC4	2
4	161701	RIGHT FORMING PUNCH TO SPREAD OUT AND CUT	1
4a	150210	REDUCED CAPSCREW M4X10	2
5	161702	LEFT FORMING PUNCH TO SPREAD OUT AND CUT	1
5a	150210	REDUCED CAPSCREW M4X10	2
6	180107	SAFETY PROTECTION FOR PITCHES FROM 7.62 TO 10.16	1
7	500070	SCREW TBEI M5X8	3

**11.3.12. DETAILED DRAWING OF PREFORMING UNIT COD. 181800
TO REDUCE PITCH AND CUT**

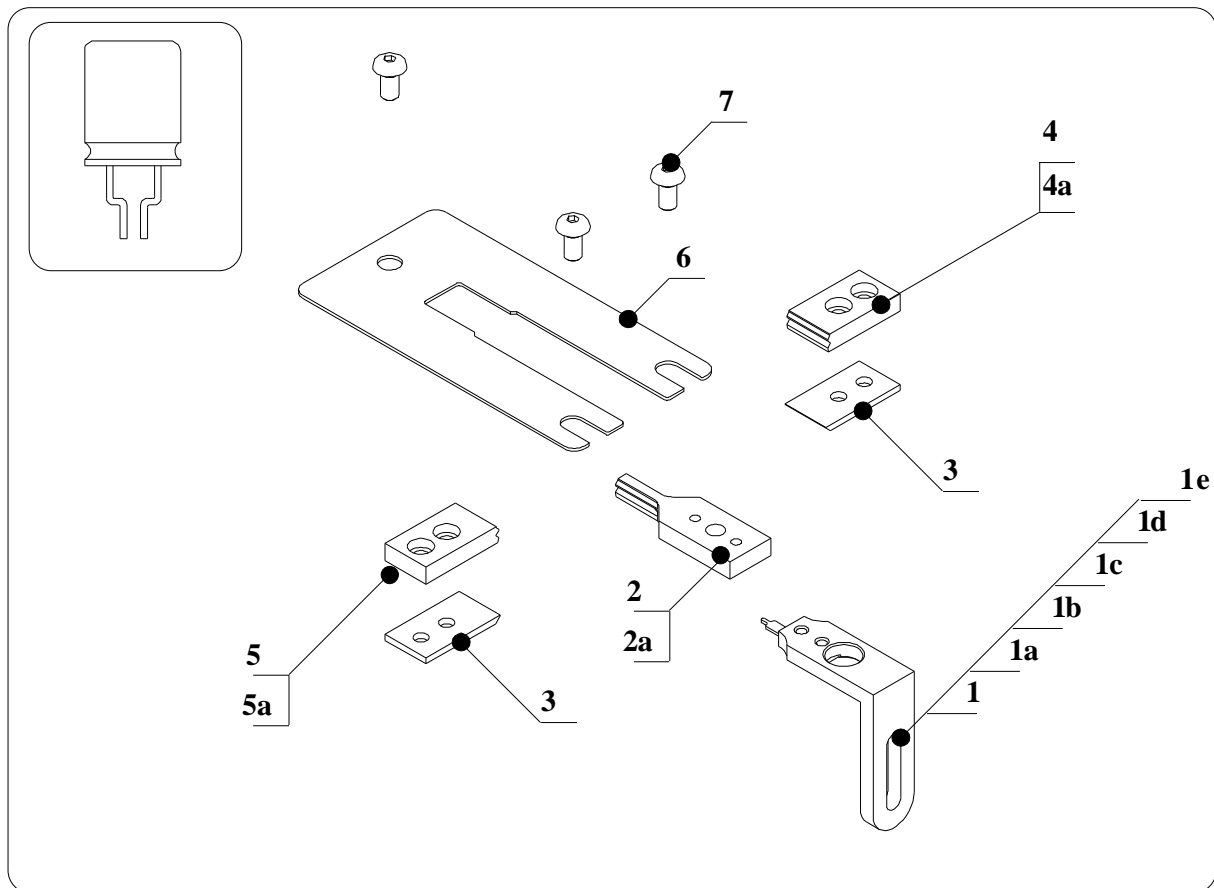

11.3.12.1 DETAILED SPARE PARTS LIST OF PREFORMING UNIT COD. 181800

Ref.	Item	Description	Qty
<u>1</u>	<u>180040</u>	<u>COMPLETE PREFORMING ADJUSTER FROM P=2 TO P=10,16</u>	<u>1</u>
1a	160018	REFERENCE HOLDER FROM P=2 TO P=10,16	1
1b	160019	PREFORMING REFERENCE FROM P=2 TO P=10,16	1
1c	500006	CS SCREW M3X8	2
1d	780517	KNOB FC-M3	1
1e	160047	SCREW TS M3x10	1
2	161803	DIE TO REDUCE PITCH AND CUT	1
2a	550012	BH SCREW M5X15	1
3	160607	CUTTING BLADE TP/SC4	2
4	161801	RIGHT FORMING PUNCH TO REDUCE PITCH AND CUT	1
4a	150210	REDUCED CAPSCREW M4X10	2
5	161802	LEFT FORMING PUNCH TO REDUCE PITCH AND CUT	1
5a	150210	REDUCED CAPSCREW M4X10	2
6	180107	SAFETY PROTECTION FOR PITCHES FROM 7.62 TO 10.16	1
7	500070	SCREW TBEI M5X8	3

**11.3.13. DETAILED DRAWING OF PREFORMING UNIT COD. 182100
TO 220 CENTER LEAD SPREAD & CUT**

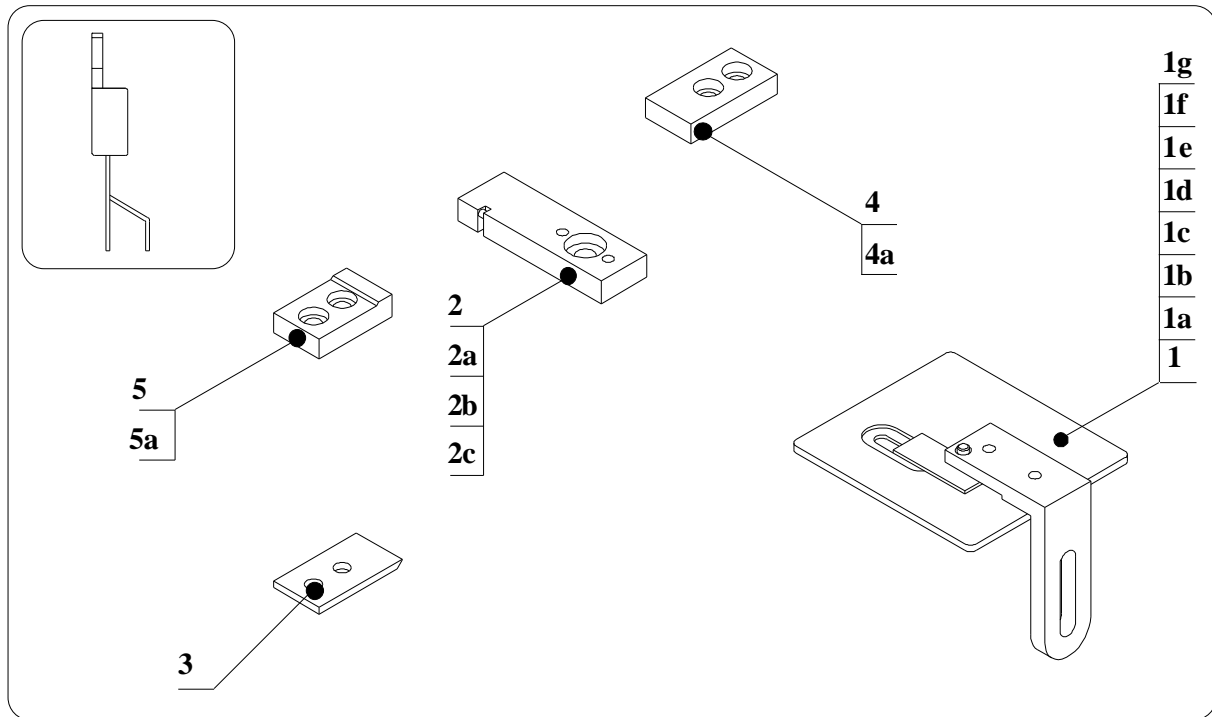

11.3.13.1 DETAILED SPARE PARTS LIST OF PREFORMING UNIT COD. 182100

Ref.	Item	Description	Q.ty
1	180042	COMPLETE HEIGHT ADJUSTER FOR COMP. TO220	1
1a	160024	HEIGHT ADJUSTER HOLDER FOR TO220 AND 90° BENDING CENT. LEAD SPREAD	1
1b	160031	PLATE	1
1c	850415	SCREW PP M3X4	1
1d	160025	PREFORMING REFERENCE FOR TO220	1
1e	160047	SCREW TS M3x10	2
1f	400116	NUT M3	1
1g	780517	KNOB FC-M3	1
2	162101	DIE TO220 CENTER LEAD SPREAD ON AND CUT	1
2a	550012	BH SCREW M5X15	1
2b	152110	CYLINDRIC PIN D. 2x10	1
2c	750302	BH SCREW M5X12	1
3	160607	CUTTING BLADE TP/SC4	1
4	161403	RIGHT FORMING PUNCH	1
4a	150210	REDUCED CAPSCREW M4X10	1
5	162102	LEFT FORMING PUNCH TO220 CENT.LEAD SPREAD ON & CUT	1
5a	150210	REDUCED CAPSCREW M4X10	1

**11.3.14. DETAILED DRAWING OF PREFORMING UNIT COD. 183100
TO 220 90° BENDING CENTER LEAD OFF SET**

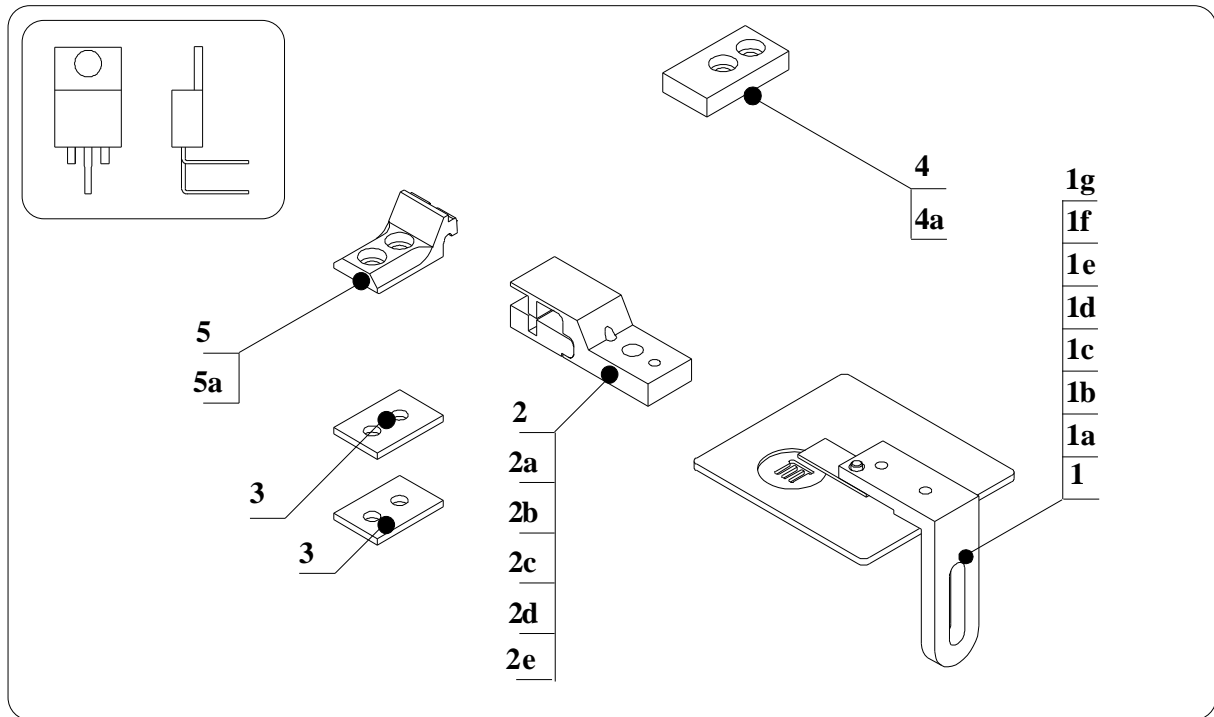

11.3.14.1 DETAILED SPARE PARTS LIST OF PREFORMING UNIT COD. 183100

Ref.	Item	Description	Q.ty
1	180043	HEIGHT ADJUSTER COMP. 90° BENDING CENTER LEAD OFF SET	1
1a	160024	HEIGHT ADJUSTER HOLDER FOR TO220 AND 90° BENDING CENT. LEAD SPREAD	1
1b	160031	PLATE	1
1c	850415	SCREW PP M3X4	1
1d	160027	PREFORMING REFERENCE FOR 90° BENDING CENTER LEAD OFF SET	1
1e	160047	SCREW TS M3x10	2
1f	400116	NUT M3	1
1g	780517	KNOB FC-M3	1
2	163101	COMPLETE DIE TO220 90° BENDING CENTER LEAD OFF SET	1
2a	162110	DIE 90° BENDING DIFFERENCED	1
2b	152110	CYLINDRIC PIN D. 2x10	1
2c	162111	SMALL BLOCK FOR DIE TO220	1
2d	160047	SCREW TS M3x10	2
2e	550012	BH SCREW M5X15	1
3	160016	THICKNESS PLATE	2
4	161403	RIGHT FORMING PUNCH	1
4a	150210	REDUCED CAPSCREW M4X10	2
5	163102	LEFT PUNCH TO220 90° BENDING CENTER LEAD OFF SET	1
5a	150210	REDUCED CAPSCREW M4X10	2

**11.3.15. DETAILED DRAWING OF PREFORMING UNIT COD. 182200
TO 220 CENTER LEAD SPREAD & LOCK**

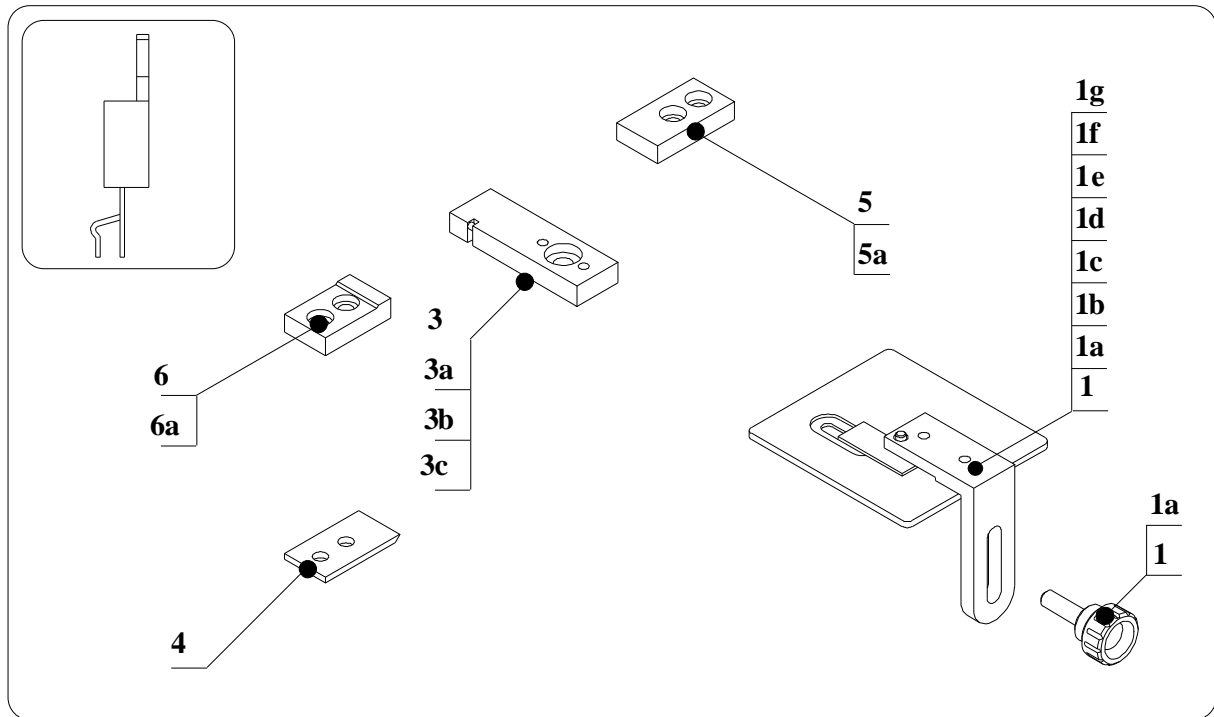

11.3.15.1 DETAILED SPARE PARTS LIST OF PREFORMING UNIT COD. 182200

Ref.	Item	Description	Qty
1	180042	COMPLETE HEIGHT ADJUSTER FOR COMP. TO220	1
1a	160024	HEIGHT ADJUSTER HOLDER FOR TO220 AND 90° BENDING CENT. LEAD SPREAD	1
1b	160031	PLATE	1
1c	850415	SCREW PP M3X4	1
1d	160025	PREFORMING REFERENCE FOR TO220	1
1e	160047	SCREW TS M3x10	2
1f	400116	NUT M3	1
1g	780517	KNOB FC-M3	1
2	162201	COMPLETE DIE TO220 CENTER LEAD SPREAD & LOCK	1
2a	162203	DIE TO220 CENTER LEAD SPREAD & LOCK	1
2b	152110	CYLINDRIC PIN D. 2x10	1
2c	750302	BH SCREW M5X12	1
3	160607	CUTTING BLADE TP/SC4	1
4	161403	RIGHT FORMING PUNCH	1
4a	150210	REDUCED CAPSCREW M4X10	2
5	162202	LEFT FORMIGN PUNCH TO220 CENT.LEAD SPREAD & LOCK	1
5a	150210	REDUCED CAPSCREW M4X10	2

**11.3.16. DETAILED DRAWING OF PREFORMING UNIT COD. 182300
TO 220 CENTER LEAD SPREAD & 3 LEAD LOCK**

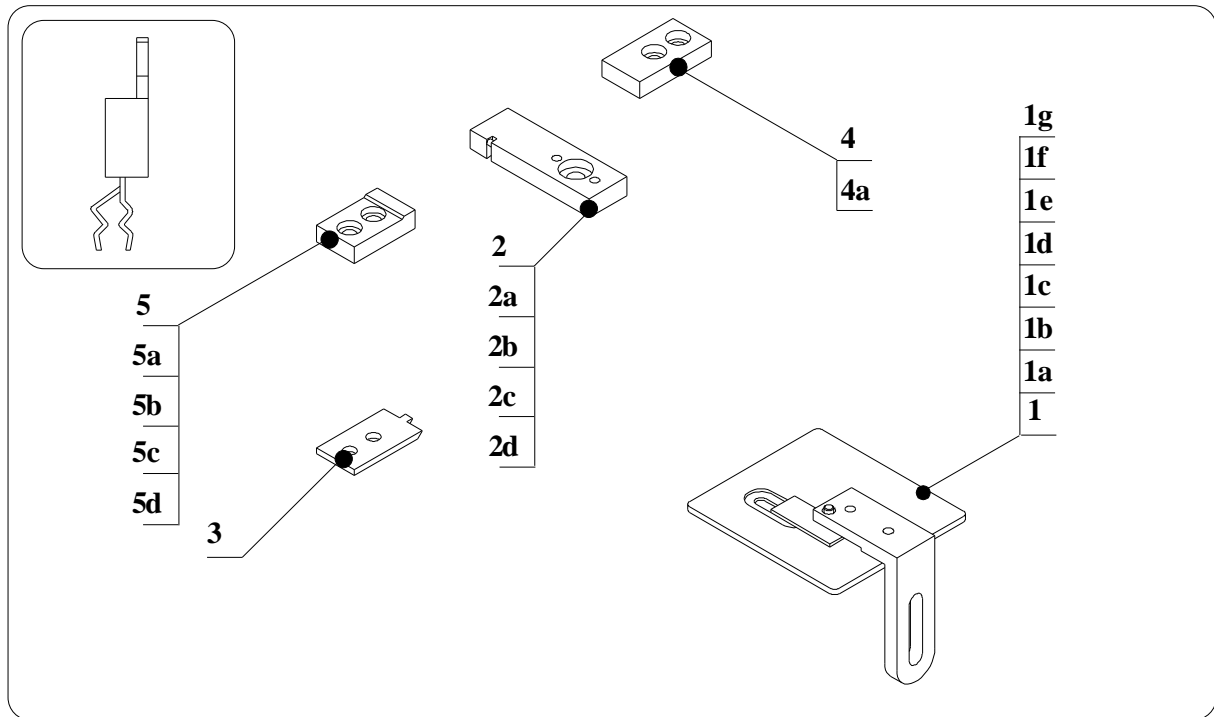

11.3.16.1 DETAILED SPARE PARTS LIST OF PREFORMING UNIT COD. 182300

Ref.	Item	Description	Qty
1	180048	ADJUSTER/REFERENCE + POSITION. CENTRE LEAD SPREAD-DOUBLE KINK ON 3 LEADS	1
1a	160026	PREFORMING REFERENCE/CENTRE LEAD OFF SET DOUBLE KINK ON 3 LEADS	1
1b	160031	PLATE	1
1c	850415	SCREW PP M3X4	1
1d	160025	PREFORMING REFERENCE FOR TO220	1
1e	160047	SCREW TS M3x10	2
1d	400116	NUT M3	1
1g	780517	KNOB FC-M3	1
2	162301	COMPLETE DIE TO220 CENTER LEAD SPREAD & 3 LEAD LOCK	1
2a	550012	BH SCREW M5X15	1
2b	163005	CAPSCREW M2x10	1
2c	162111	SMALL BLOCK FOR DIE TO220	1
3	162305	LEFT CUTTING BLADE TO220 CENT.LEAD SPREAD & 3 LEAD LOCK	1
4	161403	RIGHT FORMING PUNCH	1
4a	150210	REDUCED CAPSCREW M4X10	2
5	162303	COMPLETE LEFT FORMING PUNCH TO220 CENT.LEAD SPREAD & 3 LEAD LOCK	1
5a	150210	REDUCED CAPSCREW M4X10	2
5b	163005	CAPSCREW M2x10	1
5c	162304	INSERT FOR PUNCH TO220 CENTER LEAD SPREAD & 3 LEAD LOCK	1

11.3.17. DETAILED DRAWING OF PREFORMING UNIT COD.182400
TO 220 stand off/lock in 3 leads in line

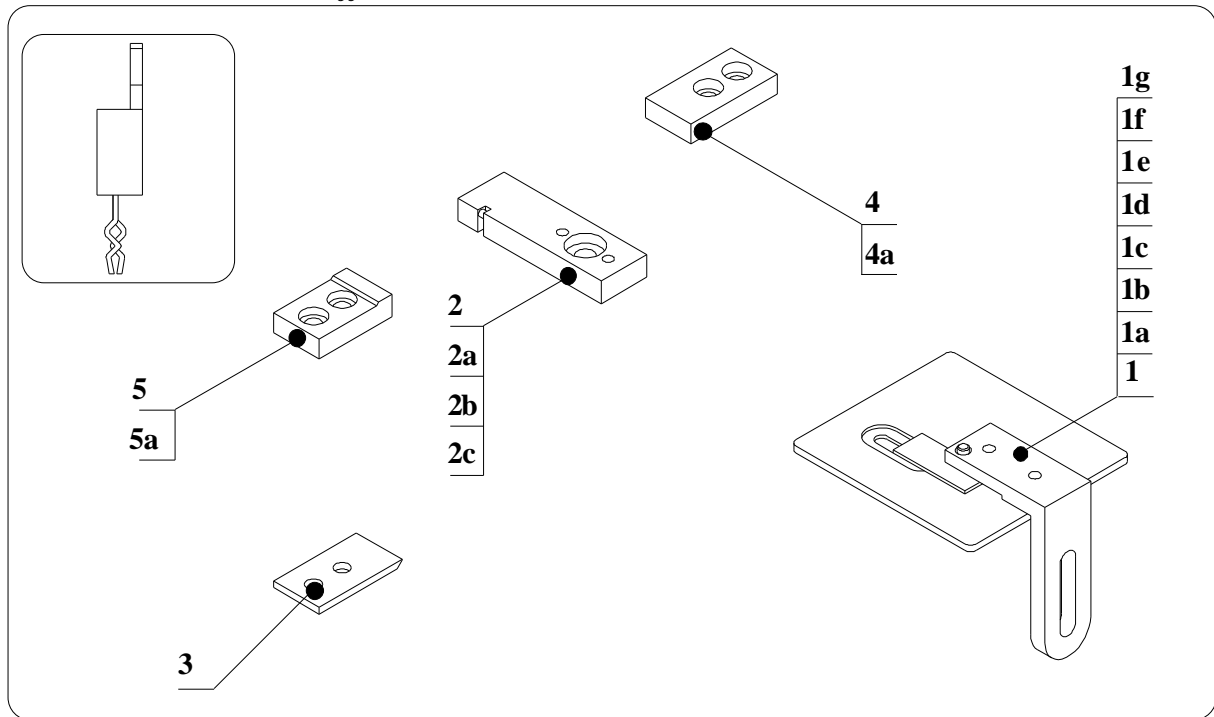

11.3.19.1 DETAILED SPARE PARTS LIST OF PREFORMING UNIT COD. 182400

Ref.	Item	Description	Qty
1	180042	<u>COMPLETE HEIGHT ADJUSTER FOR COMP. TO220</u>	1
1a	160024	HEIGHT ADJUSTER HOLDER FOR TO220 AND 90° BENDING CENT. LEAD SPREAD	1
1b	160031	PLATE	1
1c	850415	SCREW PP M3X4	1
1d	160025	PREFORMING REFERENCE FOR TO220	1
1e	160047	SCREW TS M3x10	2
1f	400116	NUT M3	1
1g	780517	KNOB FC-M3	1
2	162401	<u>COMPLETE DIE TO220 STAND OFF LOCK IN 3 LEAD IN LINE</u>	1
2a	162402	DIE STAND OFF LOCK IN 3 LEAD	1
2b	152402	INSERT FOR DIE TO220 STAND OFF LOCK IN	1
2c	163005	CAPSCREW M2x10	1
2d	750302	BH SCREW M5X12	1
3	160607	CUTTING BLADE TP/SC4	1
4	161403	RIGHT FORMING PUNCH	1
4a	150210	REDUCED CAPSCREW M4X10	2
5	162403	<u>COMPLETE LEFT FORMING PUNCH TO220 STAND OFF LOCK IN 3 LEAD IN LINE</u>	1
5a	162404	PUNCH STAND OFF LOCK IN 2 LEAD	1
5b	152404	INSERT FOR PUNCH TO220 STAND OFF LOCK IN 3 LEAD IN LINE	1
5c	163005	CAPSCREW M2x10	1
5d	150210	REDUCED CAPSCREW M4X10	2

11.3.18. DETAILED DRAWING OF PREFORMING UNIT COD. 182500
TO 92 center lead spread and cut

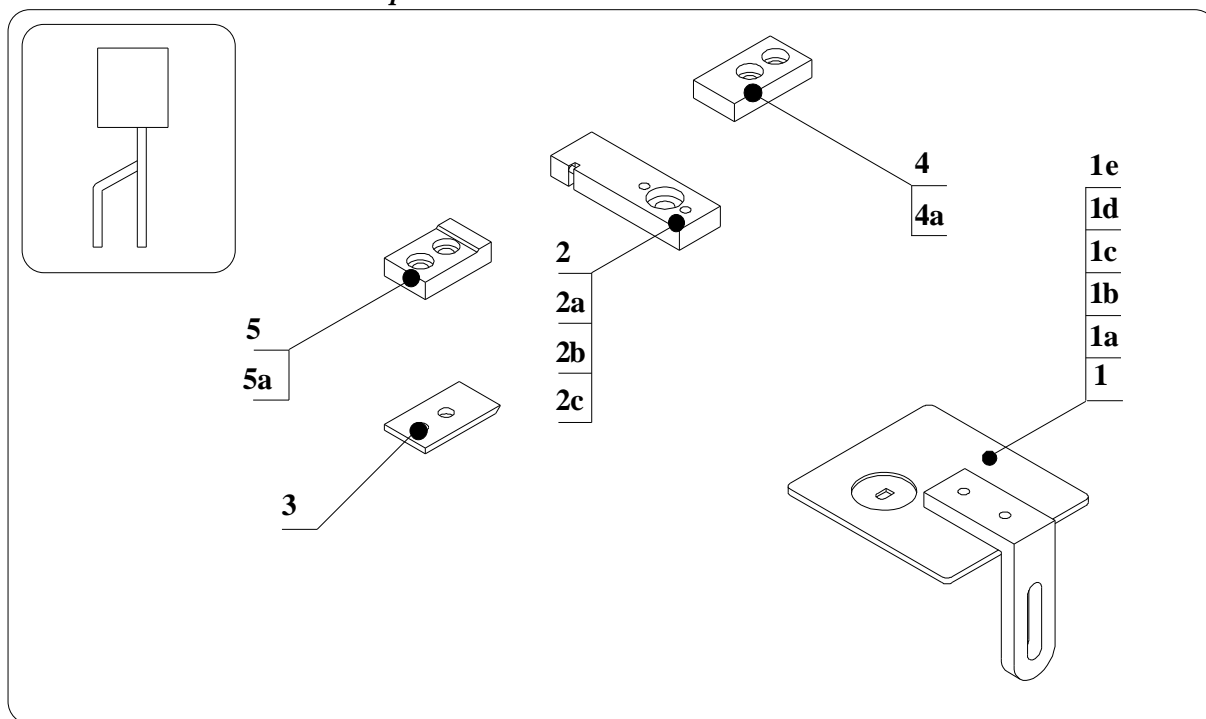

11.3.18.1 DETAILED SPARE PARTS LIST OF PREFORMING UNIT COD. 182500

Ref.	Item	Description	Qty
1	180044	COMPLETE PREFORMING ADJUSTER TO92	1
1a	160021	REFERENCE HOLDER FOR SMD / 90° BENDING/ TO220	1
1b	160029	PREFORMING REFERENCE TO92	1
1c	160047	SCREW TS M3x10	2
1d	400116	NUT M3	1
1e	780517	KNOB FC-M3	1
2	162501	COMPLETE DIE TO92 CENTER LEAD SPREAD ON & CUT	1
2a	162504	DIE TO92 CENTER LEAD SPREAD	1
2b	152110	CYLINDRIC PIN D. 2x10	1
2c	750302	BH SCREW M5X12	1
3	160607	CUTTING BLADE TP/SC4	1
4	161403	RIGHT FORMING PUNCH	1
4a	150210	RIGHT FORMING PUNCH	2
5	162502	LEFT FORMIGN PUNCH TO92 CENTER LEAD SPREAD ON & CUT	1
5a	150210	REDUCED CAPSCREW M4X10	2

11.3.19. DETAILED DRAWING OF PREFORMING UNIT COD. 182600 TO 92 center lead spread and lock

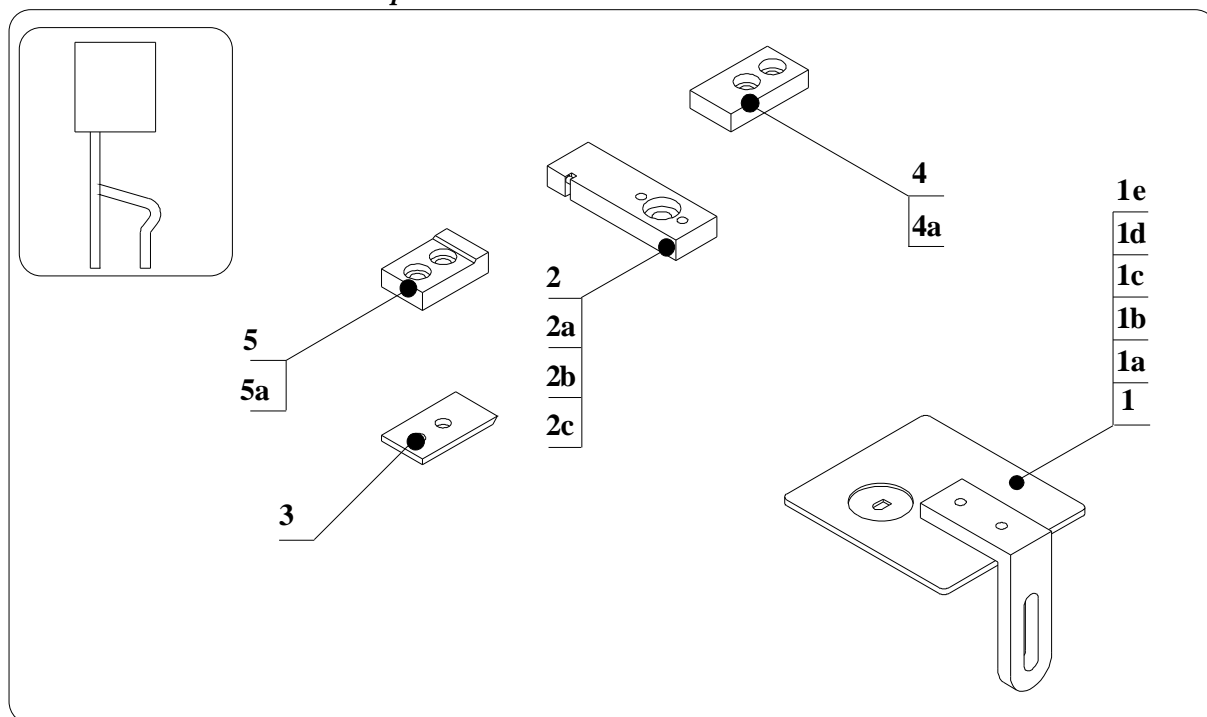

11.3.19.1 DETAILED SPARE PARTS LIST OF PREFORMING UNIT COD. 182600

Ref.	Item	Description	Qty
1	180044	COMPLETE PREFORMING ADJUSTER TO92	1
1a	160021	REFERENCE HOLDER FOR SMD / 90° BENDING/ TO220	1
1b	160029	PREFORMING REFERENCE TO92	1
1c	160047	SCREW TS M3x10	2
1d	400116	NUT M3	1
1e	780517	KNOB FC-M3	1
2	162601	COMPLETE DIE TO92 CENTER LEAD SPREAD & LOCK	1
2a	162603	DIE TO92 CENTER LEAD SPREAD & LOCK	1
2b	152110	CYLINDRIC PIN D. 2x10	1
2c	750302	BH SCREW M5X12	1
3	160607	CUTTING BLADE TP/SC4	1
4	161403	RIGHT FORMING PUNCH	1
4a	150210	REDUCED CAPSCREW M4X10	2
5	162602	LEFT FORMING PUNCH TO92 CENTER LEAD SPREAD & LOCK	1
5a	150210	REDUCED CAPSCREW M4X10	2

11.3.20. DETAILED DRAWING OF PREFORMING UNIT COD. 182700 TO 92 center lead spread & 3 leads lock

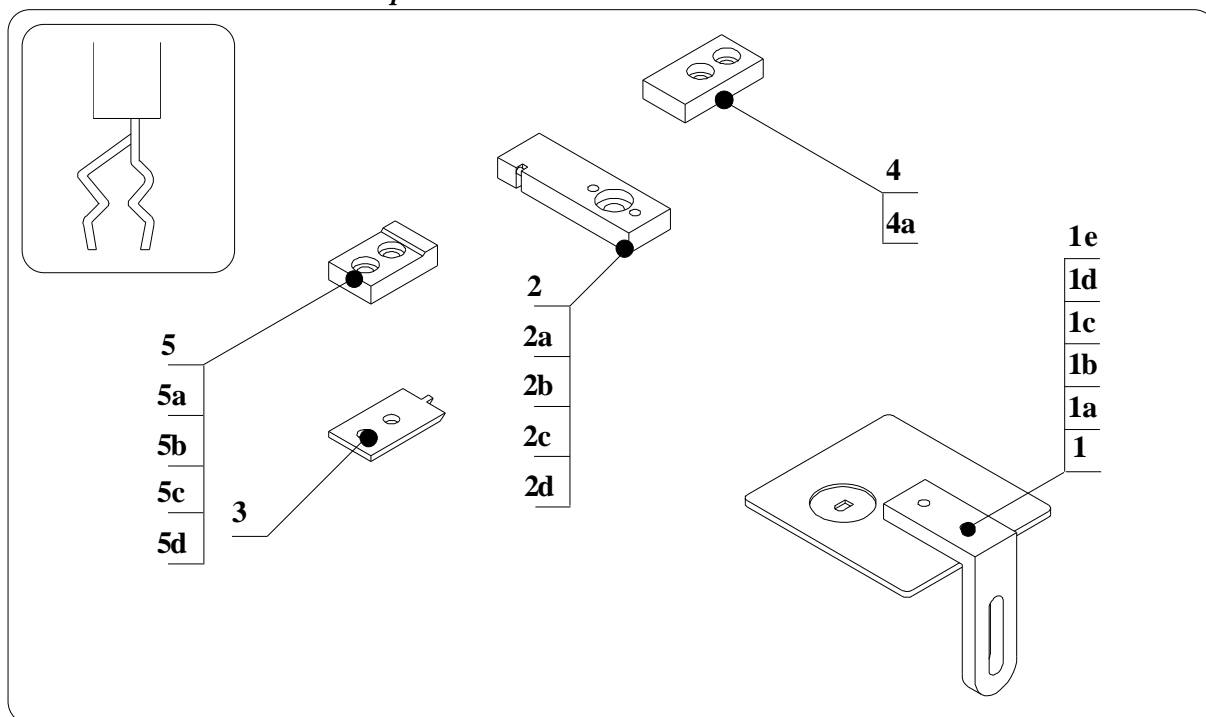

11.3.20.1 DETAILED SPARE PARTS LIST OF PREFORMING UNIT COD. 182700

Ref.	Item	Description	Qty
<u>1</u>	<u>160044</u>	<u>COMPLETE PREFORMING ADJUSTER TO92</u>	<u>1</u>
1a	160021	REFERENCE HOLDER FOR SMD / 90° BENDING/ TO220	1
1b	160029	PREFORMING REFERENCE TO92	1
1c	160047	SCREW TS M3x10	2
1d	400116	NUT M3	1
1e	780517	KNOB FC-M3	1
<u>2</u>	<u>162701</u>	<u>COMPLETE DIE TO92 CENTER LEAD SPREAD & 3 LEAD LOCK</u>	<u>1</u>
2a	162702	DIE TO92 STAND OFF LOCK IN 2 LEAD	1
2b	152702	INSERT FOR DIE TO92 CENTRE LEAD SPREAD DOUBLE KINK ON 3 LEADS	1
2c	163005	CAPSCREW M2x10	1
2d	750302	BH SCREW M5X12	1
3	162705	LEFT CUTTING BLADE TO92 CENTER LEAD SPREAD & 3 LEAD LOCK	1
4	161403	RIGHT FORMING PUNCH	1
4a	150210	REDUCED CAPSCREW M4X10	2
<u>5</u>	<u>162703</u>	<u>COMPLETE LEFT FORMING PUNCH TO92 CENTER LEAD SPREAD & 3 LEAD LOCK</u>	<u>1</u>
5a	162706	PUNCH TO92 STAND OFF LOCK IN 2 LEAD	1
5b	162704	INSERT FOR PUNCH TO92	1
5c	163005	CAPSCREW M2x10	1
5d	150210	REDUCED CAPSCREW M4X10	2

11.3.21. DETAILED DRAWING OF PREFORMING UNIT COD. 182800
TO 92 stand off/lock in 3 leads in line

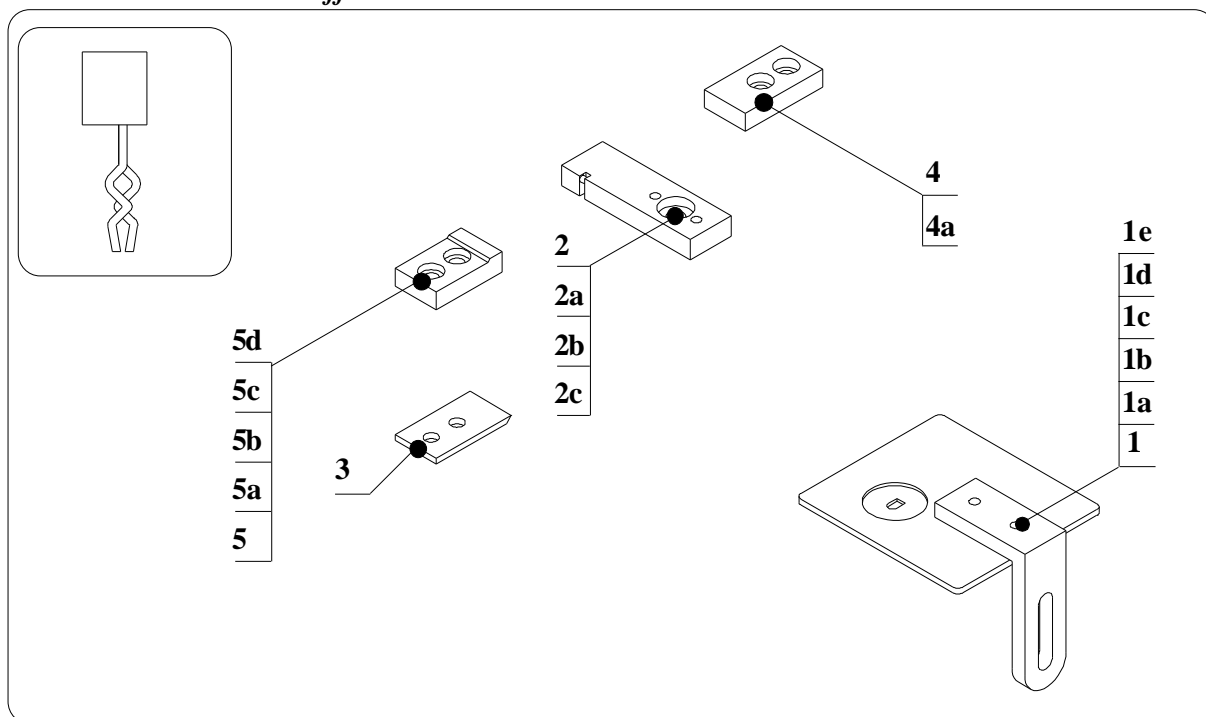

11.3.21.1 DETAILED SPARE PARTS LIST OF PREFORMING UNIT COD. 182800

Ref.	Item	Description	Qty
1	180044	<u>COMPLETE PREFORMING ADJUSTER TO92</u>	1
1a	160021	REFERENCE HOLDER FOR SMD / 90° BENDING/ TO220	1
1b	160029	PREFORMING REFERENCE TO92	1
1c	160047	SCREW TS M3x10	2
1d	400116	NUT M3	1
1e	780517	KNOB FC-M3	1
2	162801	<u>COMPLETE DIE TO92 STAND OFF LOCK IN 3LEAD IN LINE</u>	1
2a	162802	DIE TO92 STAND OFF LOCK IN	1
2b	152802	INSERT FOR DIE TO92	1
2c	163005	CAPSCREW M2x10	1
2d	750302	BH SCREW M5X12	1
3	160607	CUTTING BLADE TP/SC4	1
4	161403	RIGHT FORMING PUNCH	1
4a	150210	REDUCED CAPSCREW M4X10	2
5	162803	<u>COMPLETE LEFT FORMING PUNCH TO92 STAND OFF LOCK IN 3LEAD IN LINE</u>	1
5a	162804	LEFT PUNCH TO92 STAND OFF LOCK IN	1
5b	152804	INSERT FOR PUNCH TO92	1
5c	163005	CAPSCREW M2x10	1
5c	150210	REDUCED CAPSCREW M4X10	2